

Chapter

11

SEMICONDUCTOR OPTOELECTRONICS

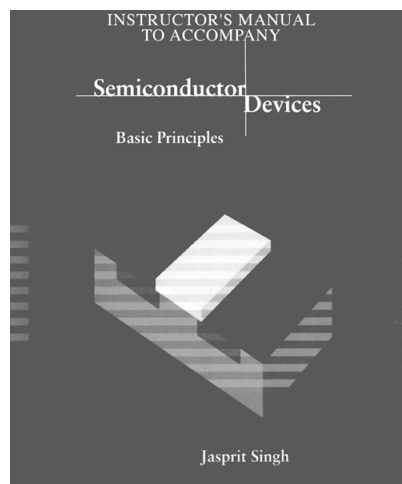

Semiconductor based optoelectronic devices form an important component of modern information age. The following figures provide an overview of important optoelectronic processes and devices.

ADVANTAGES OF OPTICAL DEVICES

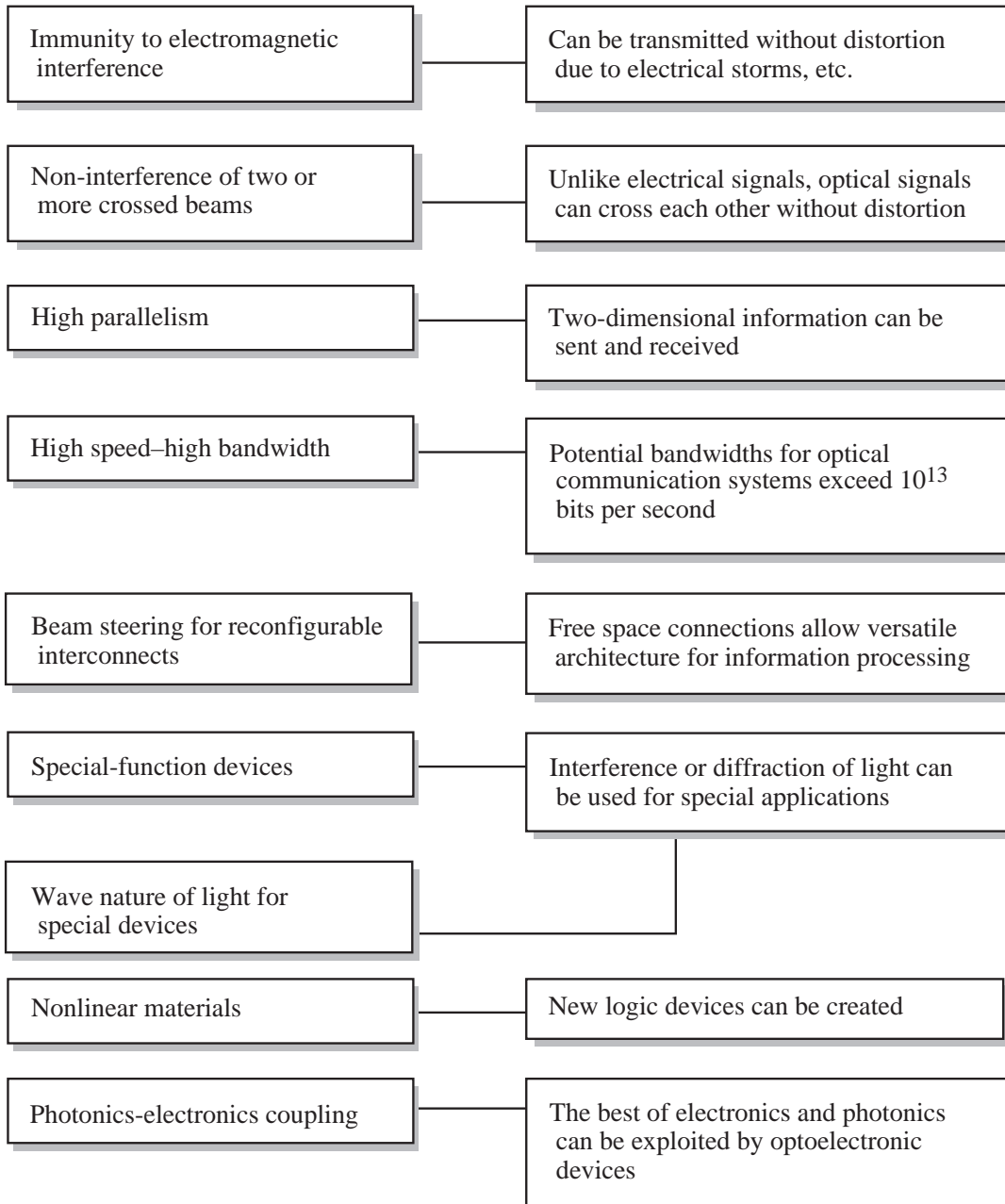

Challenges: How does one harness the tremendous potential?

OPTOELECTRONICS: MOTIVATIONS FROM SYSTEM DEMANDS

- DISPLAY APPLICATIONS: Light emitters covering red, green, blue
- OPTICAL MEMORIES: Short wavelength light emitters
- COMMUNICATIONS: Light emitters/detectors operating at low absorption/dispersion points of optical fibers (1.55 μm , 1.3 μm)

SEMICONDUCTOR BANDGAPS (WAVELENGTHS) AND HUMAN EYE RESPONSE

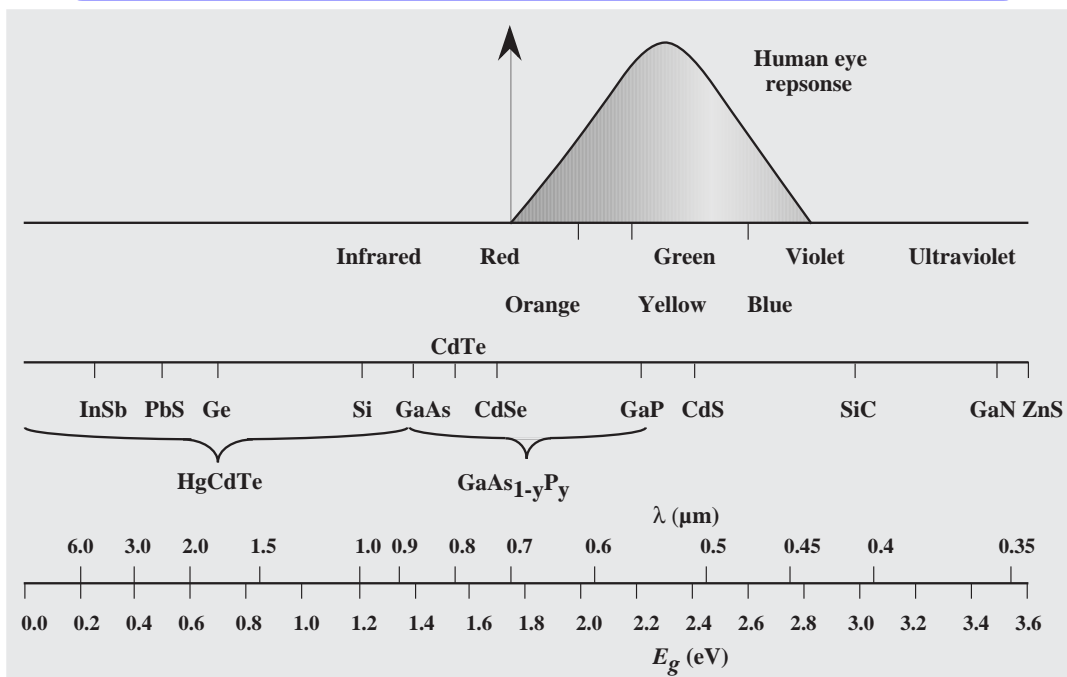

LIGHT ABSORPTION IN SEMICONDUCTORS

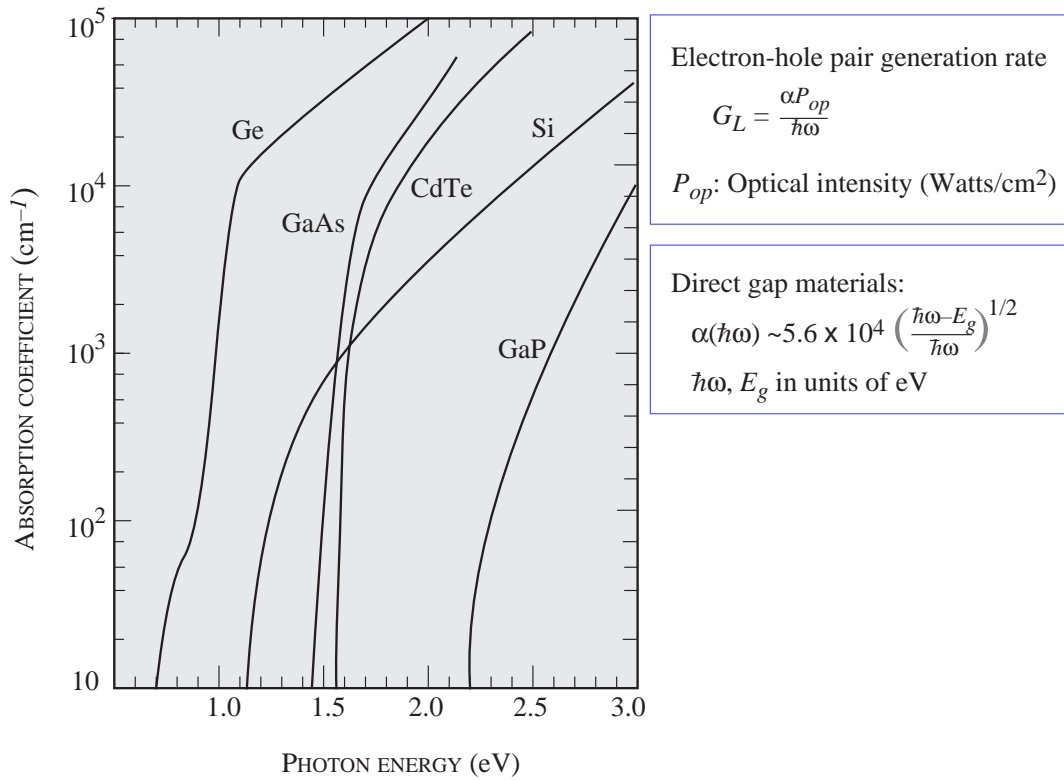
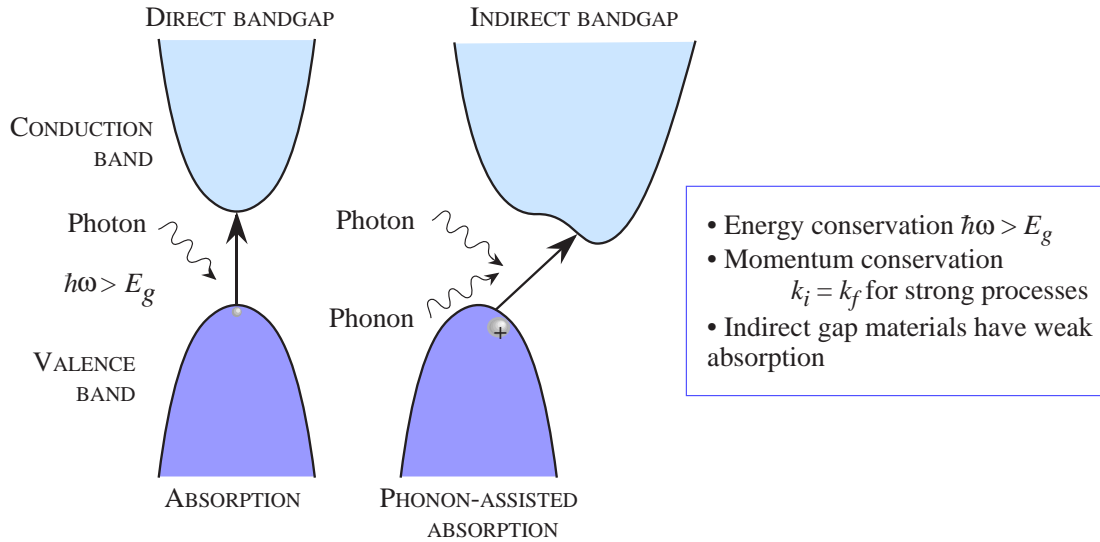

P-I-N PHOTODETECTORS

The detector is reverse biased to collect any electron-hole pairs created by light absorption.

Photocurrent:

$$I_L = eAJ_{ph}(0)[1 - \exp(-\alpha W)]$$

J_{ph} = Optical photon particle current

W = Depletion region

A = Device area

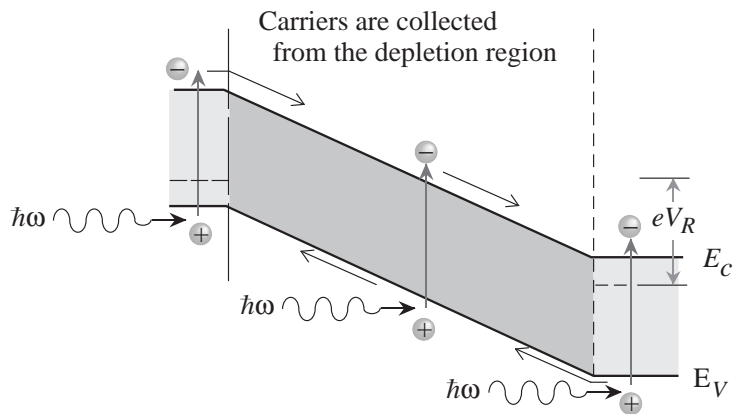
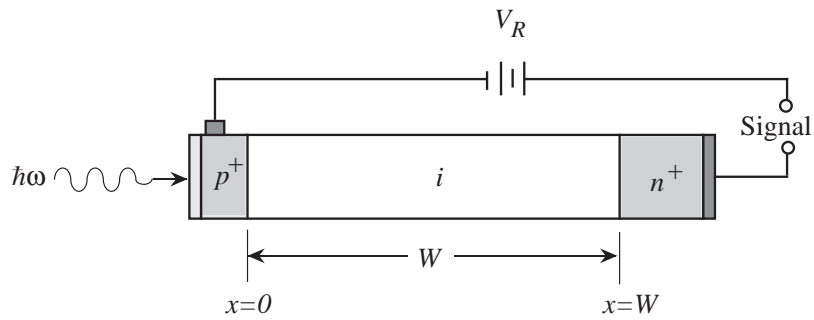

SEMICONDUCTOR LIGHT EMITTERS FOR COMMUNICATION APPLICATIONS

Light emitters for long haul communication systems must emit light at $\lambda = 1.55 \mu\text{m}$ or $\lambda = 1.3 \mu\text{m}$.

1.55 μm : Lowest loss point in optical fibers

1.3 μm : Lowest dispersion point in optical fibers

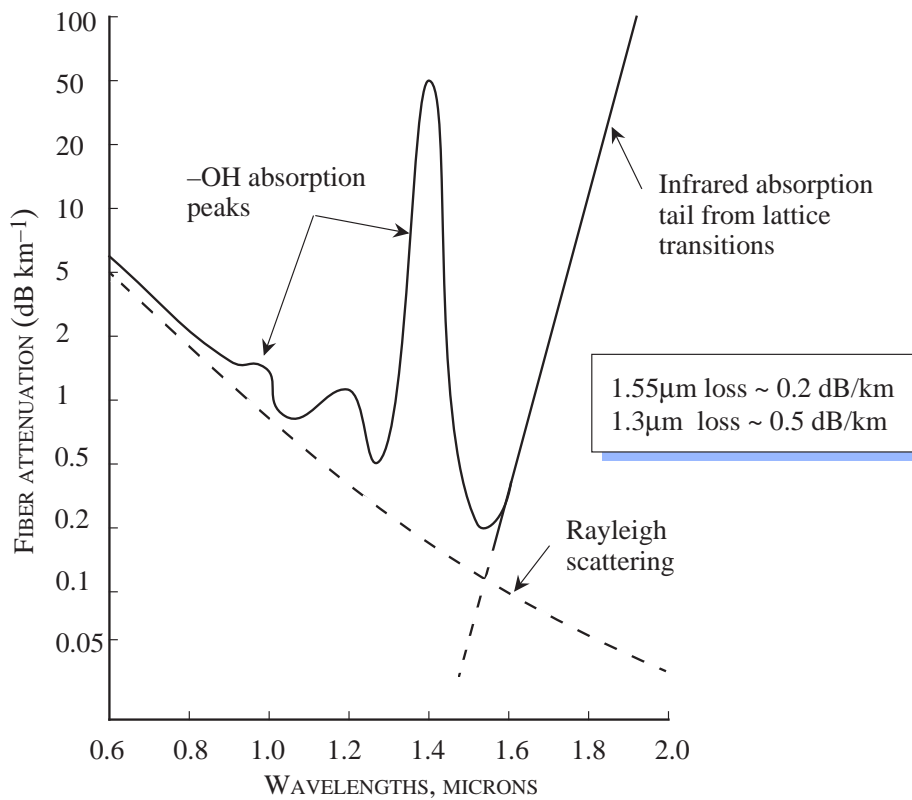

- GaAs lasers ($\lambda \sim 0.88 \mu\text{m}$) are used for local area networks where distances to be covered are only a few kilometers.

- InGaAsP lasers are used for long haul communication. Optical pulses travel ~40-50 km and are then separated by repeater lasers. Optical fiber amplifiers are also used to boost the signal.

LIGHT-EMITTING DIODE: GENERAL PRINCIPLES

The LED is a forward biased p - n diode. Electrons (holes) are injected into p -side (n -side) region where they recombine with holes (electrons) to emit photons.

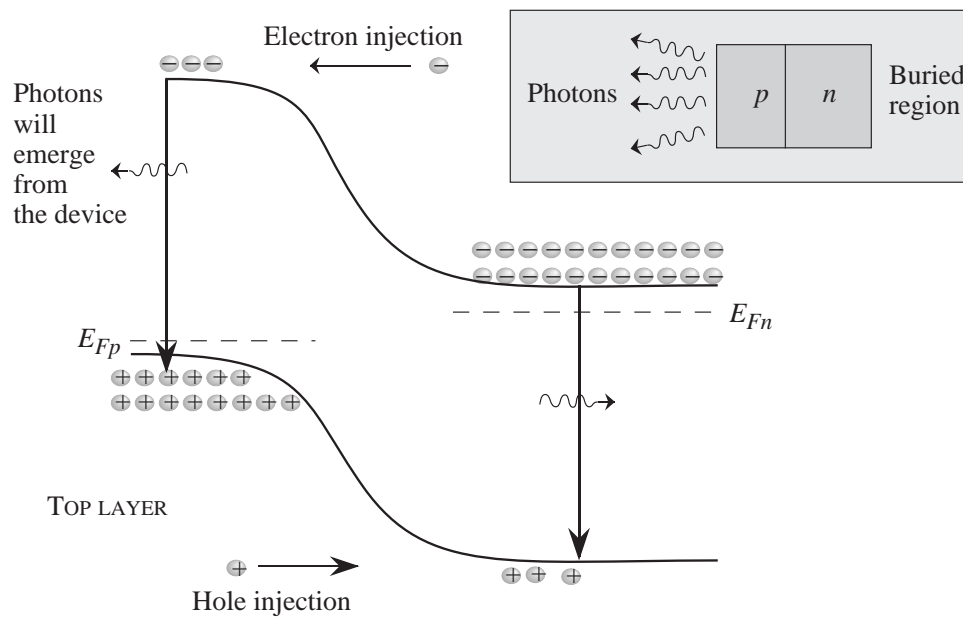

Emitted photon energy $\sim E_g$

Emitted spectral linewidth $\sim k_B T$

Upper limit to LED switching time ~ 1 ns \leftarrow electron-hole recombination time

LED: ELECTRON-HOLE RECOMBINATION TIME

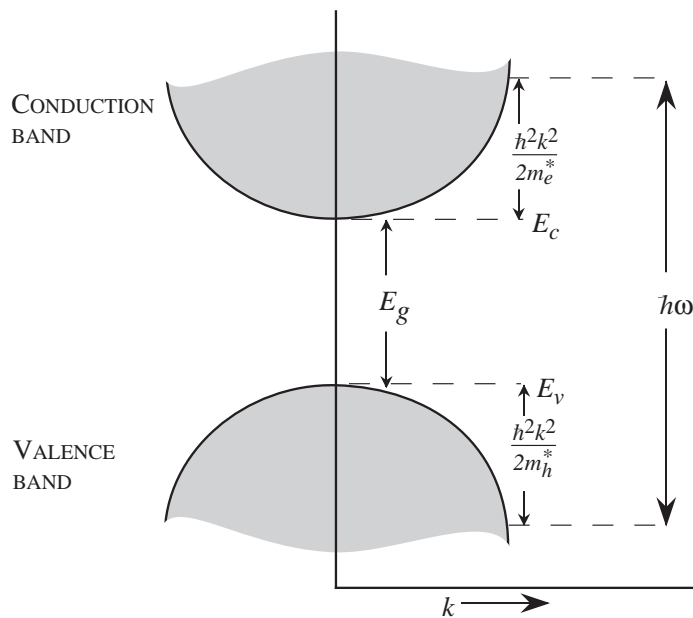

- Electrons and holes recombine in LEDs via a process called *spontaneous recombination*.
- Energy-momentum conservation rules apply.

Recombination rate $\propto f^e(k) \cdot f^h(k)$

$f^e(k)$: probability of finding an electron with momentum $\hbar k$

$f^h(k)$: probability of finding a hole with momentum $\hbar k$

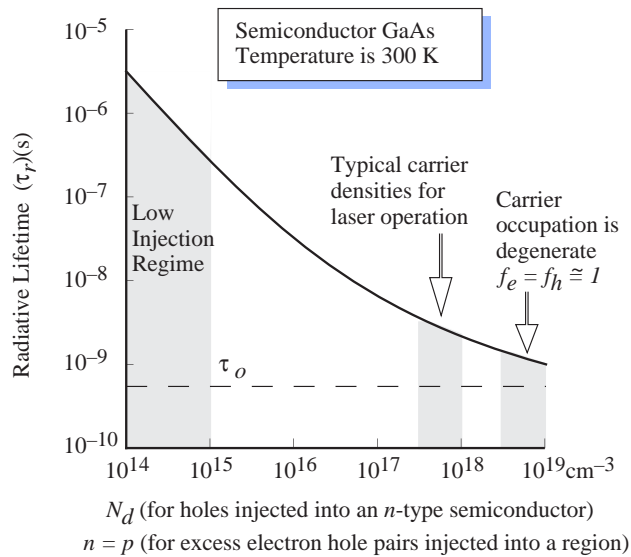

- Electrons-holes recombination time is a function of carrier density.
- At high carrier densities the e - h recombination time approaches a nanosecond in most direct gap semiconductors.

STIMULATED EMISSION AND SPONTANEOUS EMISSION

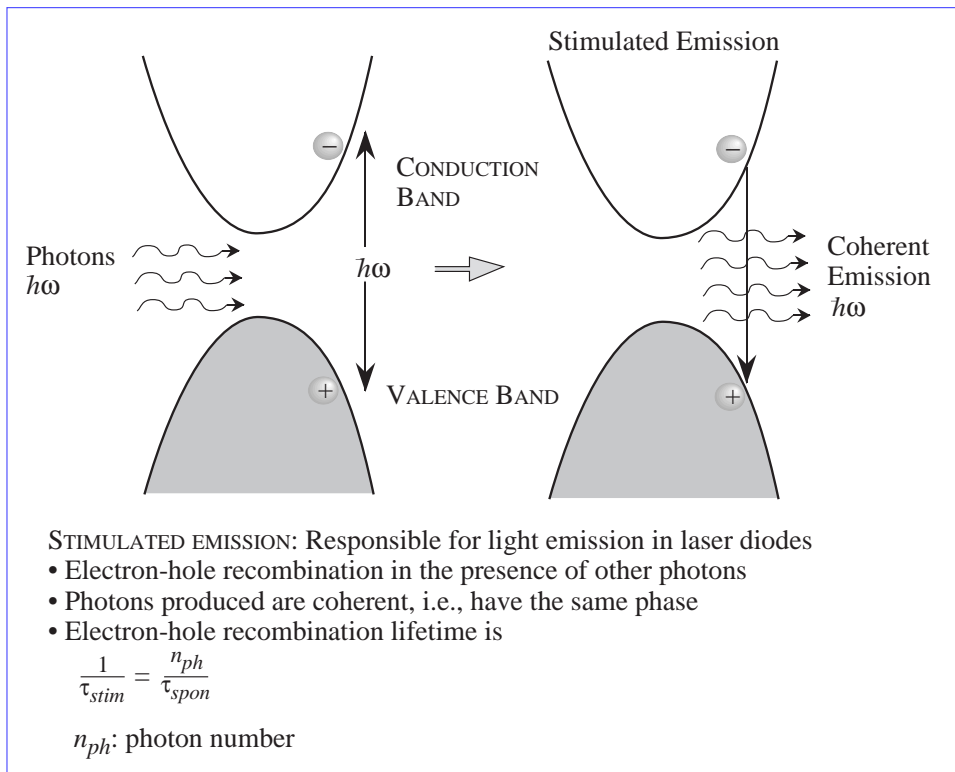
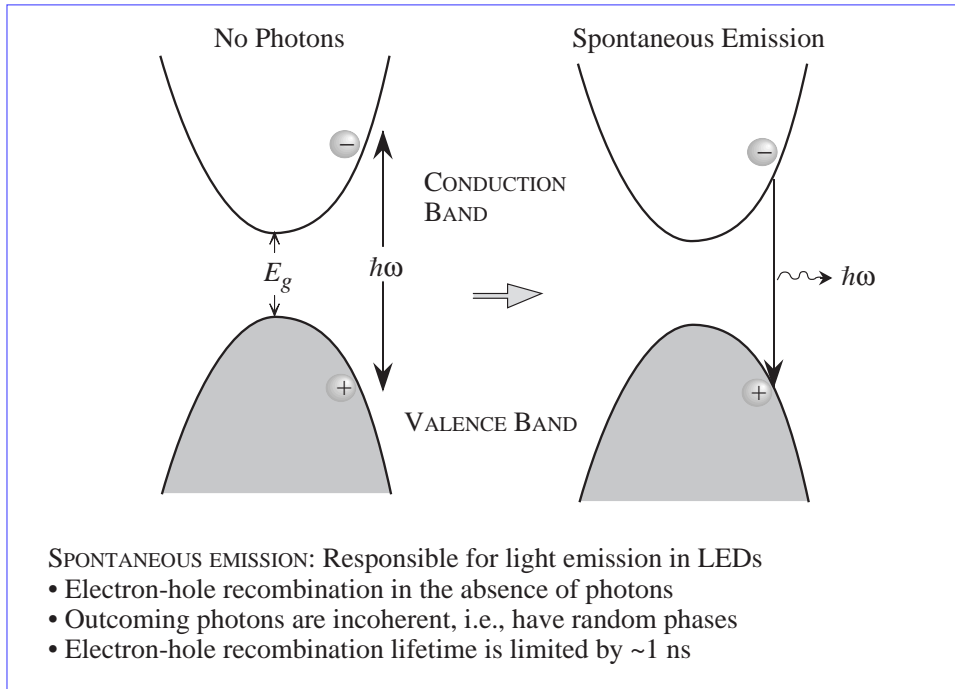

THE LASER STRUCTURE: FORWARD BIASED P-N DIODE AND OPTICA CAVITY

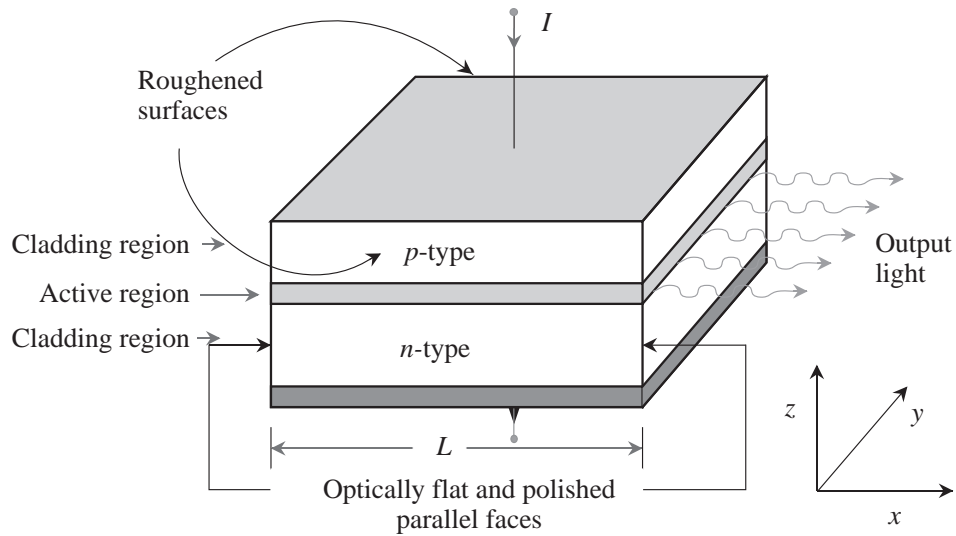

Optical cavity, produced by cleaving the crystal causes photons to be reflected back into the cavity. The photon build-up starts the stimulated emission responsible for lasing

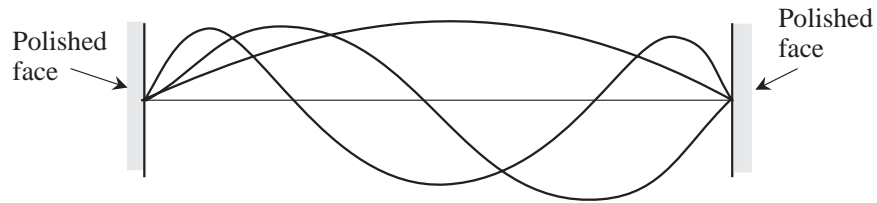

Optical modes in the cavity

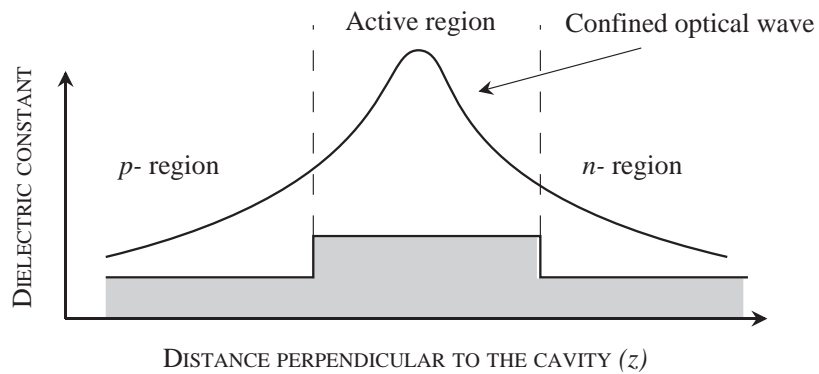

The light wave is confined in the cavity by the waveguide of the laser structure

LASER OPERATION: GAIN AND LIGHT OUTPUT

- Gain = emission coefficient – absorption coefficient
- As more and more electrons and holes are injected into the active region of the laser the gain increases.
- When the gain overcomes the laser in the cavity, photon build-up occurs and lasing starts.

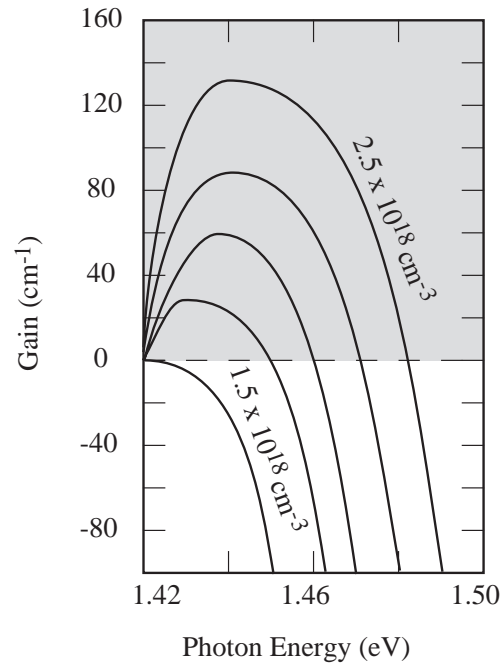

Light output in the *lasing mode* is very small below threshold. It increases rapidly once the laser is in the above threshold state.

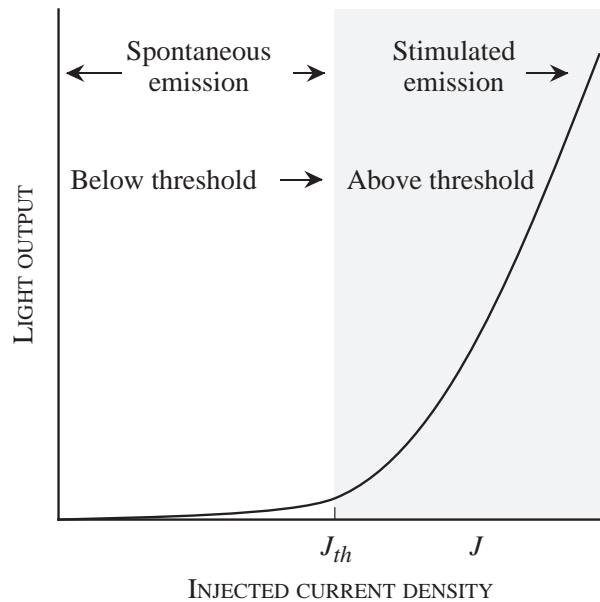

SPECTRAL OUTPUT OF A SEMICONDUCTOR LASER

