

EECS 461, Fall 2009, Problem Set 1¹

issued: September 17, 2009

due: September 24, 2009

1. Consider a thermocouple that gives an output voltage of $0.5 \text{ mV}/^\circ\text{F}$. Suppose we wish to measure temperatures that range from -20°F to 120°F with a resolution of 0.5°F .
 - (a) If we pass the output voltage through an n -bit A/D converter, what word length n is required in order to achieve this resolution?
 - (b) Does your answer to (1a) change if the maximum binary value $1 \dots 1$ is used to represent V_{max} uniquely? Explain.
 - (c) Return to the scheme of (1a), and choose the minimum value of n that will achieve the desired resolution. The binary representation of -20°F is equal to zero. What is the lowest temperature that has a nonzero binary representation, assuming unipolar coding without centering?
 - (d) How does the answer to (1c) change if centering is used?

2. Consider a rotating wheel with *one* mark painted on it, and suppose that the wheel rotates with a constant rate R revolutions/second in a counterclockwise (CCW) direction. Suppose also that we make a movie (as with a camcorder), which consists of still photographs taken at regularly spaced intervals of T seconds. We saw in class that if $T = 1/R$, then the wheel will appear to be stationary. Furthermore, in order that the movie depicts the correct direction of rotation of the wheel, it is necessary that $T < 1/2R$. Recall the movie from [2] in which the wheel had *four* arrows, 90° apart, painted on it, and suppose also that this wheel rotates at a constant rate CCW.
 - (a). What is the smallest value of T that will now make the wheel appear stationary in the movie?
 - (b). What is the largest value T can take in order that the direction of rotation appear correctly?
 - (c). Suppose that the camcorder shoots pictures at a rate of 30 frames/second. What is the maximum value of rotation rate R for the wheel with one painted arrow that will allow the direction of rotation to appear correctly?
 - (d). Suppose again that the camcorder shoots pictures at a rate of 30 frames/second. What is the maximum value of rotation rate R for the wheel with four painted arrows that will allow the direction of rotation to appear correctly?
 - (e). How do the answers to these questions change if the wheel has N equally spaced arrows?

3. Consider a sensor that generates an analog signal which must be sampled and passed through an A/D converter. We have seen that undersampling may cause the sampled signal to look very different from the original signal. In particular, noise at frequencies greater than the Nyquist sampling rate $f_N = 1/2T$ Hz will be “aliased” and appear as low frequency signals. In Lecture 2 we discussed the use of an analog lowpass filter to remove high frequency noise from the analog signal before sampling. Such a filter is referred to as an *antialiasing filter*. We also showed in Lecture 2 how a simple lowpass filter may be constructed using an RC circuit. (Antialiasing filters may also be built with active, op-amp circuits.) Suppose we wish to sample a sinusoidal signal with a sample period equal to T seconds. The sampling frequency is equal to $\omega_S = 2\pi/T$ radians/second, or $f_S = 1/T$ Hz.
 - (a). Let $T = 0.09$ seconds, and suppose the sinusoid has frequency equal to 1 Hz: $x(t) = \sin(2\pi t)$. According to the Nyquist theorem, is it theoretically possible to reconstruct the sinusoid from its samples? That is, does the frequency of the sinusoid lie below the *Nyquist frequency* which is $f_N = 1/2T$ Hz, or $\omega_N = \pi/T$ radians/second?

¹Revised September 1, 2009.

- (b). Now suppose that the signal we wish to sample is contaminated by 8 Hz noise: $x_{noisy}(t) = \sin(2\pi t) + 0.5 \sin(16\pi t)$. How will the presence of the noise signal distort the sampled signal? What will the signal look like if the samples are passed through a D/A converter?
- (c). Use the Matlab m-file “aliasing.m” and the SIMULINK model “noisy_signal.mdl”, shown in Figure 1, to compare the time responses of the clean signal, the signal contaminated with noise, and the reconstructed signal. Are the responses you see consistent with your analysis above? Explain.

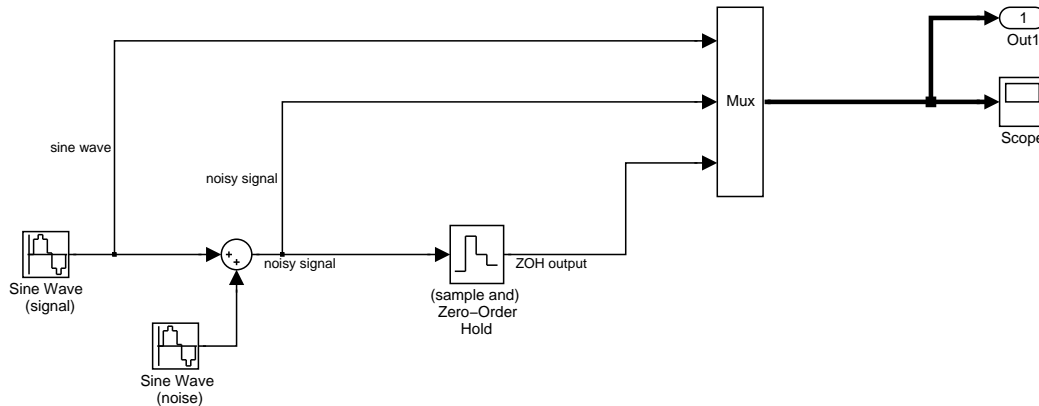

Figure 1: SIMULINK Model of Signal Reconstruction

- (d). Modify the SIMULINK model “noisy_signal.mdl” to create a new model, “filtered_signal.mdl”, shown in Figure 2, that includes a lowpass filter. The frequency response of this filter, together with the resulting reconstructed signal, may be plotted using the m-file “aliasing_w_filter.m”. What will the filtered signal look like after it is passed through a sample and hold? The lowpass filter in this figure can be adjusted by changing the parameter “ RC ”. Try various values of RC , say $RC = .001, .01, .1, 1, 10$. What trends do you see?

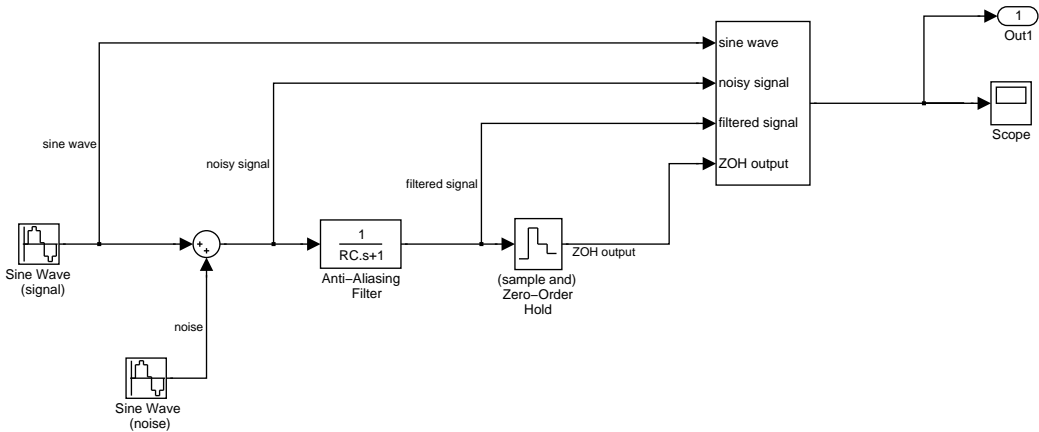

Figure 2: SIMULINK Model of Signal Reconstruction with Antialiasing Filter

- (e). Design an antialiasing filter (i.e., pick a value of RC) that will reduce the noise component of the analog signal by (approximately) a factor of 10 (-20 db). (To do so, examine the frequency response plot of the filter.) Hand in the plot showing the reconstructed signal for this filter.
- (f). Examine the frequency spectra of the noisy sinusoid, the filtered sinusoid, and the output of the ZOH. In each case, you will see peaks in the response at various frequencies. Why are these peaks located where they are? To compute the frequency spectra, you may use the Matlab file “fre-

quency_spectra.m”, together with the auxiliary Matlab file “contfft.m”, taken from [1]. Hand in one set of frequency spectra for the value of RC that achieves the desired attenuation of the noise signal.

References

- [1] E. Kamen and B. Heck. *Fundamentals of Signals and Systems using MATLAB*. Prentice Hall, 1997.
- [2] J. H. McClellan, R. W. Schafer, and M. A. Yoder. *DSP First: A Multimedia Approach*. Prentice-Hall, 1998.