

Lab Exercise 5: The Smith Chart

Contents

5-1	PRE-LAB ASSIGNMENT	78
5-2	FORMAT AND COMMENTS	78
5-3	INTRODUCTION	78
5-4	USEFUL EQUATIONS	79
5-5	EQUIPMENT	79
5-6	EXPERIMENT	79
5-6.1	Line Parameters Of A Lossless Line	79
5-6.2	Lossy And Lossless Lines On The Smith Chart	83
5-6.3	Impedance Measurements Using The Smith Chart	84
5-6.4	Impedance Matching Using A Single Stub Tuner	86
5-7	LAB WRITE-UP	90

Objective

To examine the utility of the Smith Chart and the concept of matching. The concepts of lossy versus lossless lines and impedance matching will be explored.

General concepts to be covered:

- Lossy versus lossless lines on the Smith Chart
- Relative dielectric constant and its relationship to u_p
- Single-stub matching techniques
- Smith Chart display on the network analyzer
- Transmission line parameters
- Using the Smith Chart to measure load impedances

5-1 PRE-LAB ASSIGNMENT

5-1.1 **Read** Sections 2-7, 2-9, 2-10 of the text.

5-1.2 **Work** Exercise 2.16 and Example 2-12 (not to be handed in).

5-1.3 **To be entered into your lab notebook prior to coming to lab:**
Summarize the experimental procedure (1 paragraph per section) of:

- (a) Section 5-6.1: Line Parameters Of A Lossless Line
- (b) Section 5-6.2: Lossy And Lossless Lines On The Smith Chart
- (c) Section 5-6.3: Impedance Measurements Using The Smith Chart
- (d) Section 5-6.4: Impedance Matching Using A Single-Stub Tuner

5-2 FORMAT AND COMMENTS

When printing the network-analyzer display, be sure to properly configure the printer and hardcopy output:

- Select the proper output port (see Lab Exercise 3)
- Select **Landscape** mode
- Set the resolution of the printer to 150 dpi
- Set the top margin to 25.5 mm
- Set the left margin to 25.5 mm
- Select either graph only or graph and marker table.
- Clock on line 2 of the title
- On line 1, add a descriptive title that contains the following information:
 - Section #
 - Lab station #
 - Description of load being measured (i.e., LOSSY LINE, for example).

5-3 INTRODUCTION

You have seen in class that the wave propagation properties of transmission lines are governed by several parameters. One of these parameters is the relative dielectric constant, ϵ_r . In this lab, you will measure ϵ_r for a lossless transmission line. Using the measured value of ϵ_r , you will determine the phase velocity u_p and phase constant β of the line.

There are many formats used to display the reflections caused by mismatched loads. Some of these formats include magnitude and phase, VSWR, and the Smith Chart. In this lab, we will focus on the Smith Chart. The Smith Chart is a very useful tool in microwave engineering. It allows the microwave engineer to represent the complicated equations governing the reflections at load mismatches in a very compact graphical format.

The network analyzer has the Smith Chart as one of the display options. In this lab, several different phenomena will be examined using the Smith Chart. In addition, the concept of matching will be introduced.

There are several techniques that are widely used to match loads to transmission lines. Among these techniques, three of the most common distributed-element techniques are: quarter-wave transformers, single stub tuners, and double stub tuners. The first two methods are covered in this course. The last method, double stub tuning, is covered in more advanced courses.

5-4 USEFUL EQUATIONS

$$\begin{aligned}\lambda &= u_p/f \quad (\text{m}) \\ u_p &= \omega/\beta \quad (\text{m/s}) \\ \epsilon_r &= (c/u_p)^2 \\ Z_0 &= \sqrt{L'/C'} \quad (\Omega) \\ \beta &= \omega\sqrt{\mu\epsilon} \quad (\text{rad/m}) \\ \omega\sqrt{\mu\epsilon} &= \omega\sqrt{L'C'} \quad (\text{m}^{-1})\end{aligned}$$

5-5 EQUIPMENT

Item	Part #
Cables & connectors	—
Calibration Kit	HP 85032E
Lossy line simulator	—
Network Analyzer	HP 8712C
Printer	HP DeskJet 400
Single stub tuner	—
Various Loads	—

5-6 EXPERIMENT

5-6.1 Line Parameters Of A Lossless Line

In this experiment, you will use the network analyzer to compute the line parameters of a lossless line (β (rad/s), C' (F/m), L' (H/m), u_p (m/s), and ϵ_r) by making measurements to determine ϵ_r .

Although the cable that you will use is a coaxial cable which does have some inherent loss, we will make the assumption for this experiment that $\alpha \approx 0$. We are justified in making

this assumption since the loss for this particular cable is 4.1 dB/100 ft. Since the piece of cable you are using is only 2' in length, the loss is ≈ 0.082 dB which is less than 1%.

The relative permittivity ϵ_r for the transmission line is determined by measuring u_p for the transmission line and comparing it to u_p for free space (a vacuum). Phase velocity can be determined by measuring the time (Δt) that a wave takes to travel down a transmission line of length l and return to the network analyzer. The value of ϵ_r can be found from u_p computed using the relation:

$$u_p = \frac{2l}{\Delta t} \text{ (m/s)}, \quad (5.1)$$

To measure the time delay of the cable, you will use the electrical delay feature of the network analyzer and terminate the patch cord with a load of known reflection coefficient. In this experiment, the transmission line will be terminated in a short. Recall that $\Gamma = -1$ for a short-circuit termination.

When a transmission line is placed between the network analyzer and a load termination, an electrical delay is added to the load response. The term electrical delay means that the signal has an added phase shift from traversing the transmission line. In particular, if you look at a short termination, you will see that the response is a set of concentric circles wrapping around the outside edge ($|\Gamma| = 1$ circle) of the Smith Chart.

When you add electrical delay, you are actually adding a phase correction to the received signal. The phase correction is given in terms of time. When you have added the correct amount of electrical delay, the response of the short termination will collapse to a point.

In reality, the response will collapse to what is termed a “point-like” response (as demonstrated in Fig. 5-1). This means that the response is not a true point, but is more spread out. This is due to the finite loss in the cable and connectors.

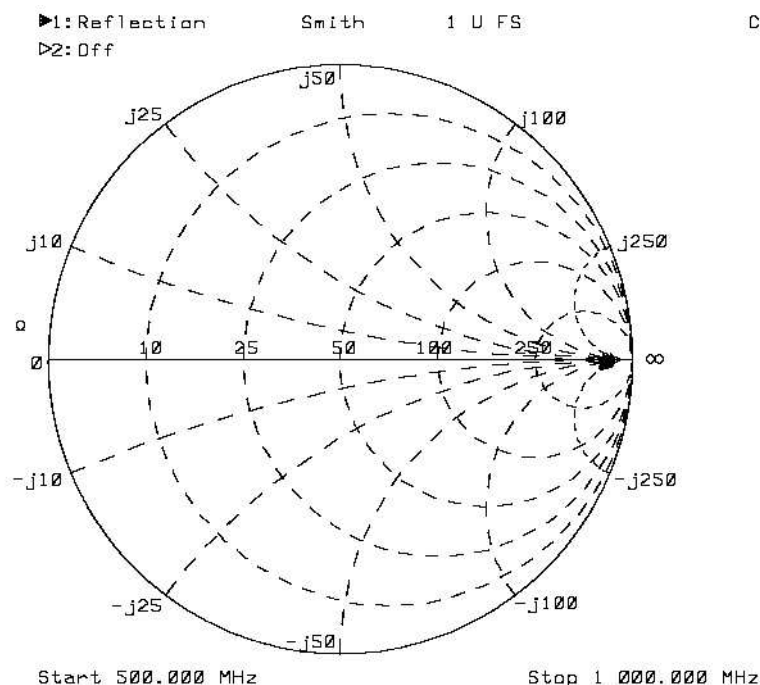

Figure 5-1: Example of a “point-like” response on the Smith Chart

Setup

This experiment requires the network analyzer, patch cord, open-circuit termination, and short-circuit termination.

Setup the experiment:

- Configure the network analyzer.
 - Press **Preset**.
 - Set the start frequency to 500 MHz.
 - Set the stop frequency to 1 GHz.
 - Set the network analyzer to measure reflection on channel 1.
 - Display the data on channel 1 in Smith Chart format:

- Press **Format**
- Press the **Smith Chart** softkey

- Perform a 1 channel calibration (no cable present).
- Save the instrument state.

Procedure

1. Measure the physical length of the patch cord (measure from the center of the connectors and add 2.6 cm for the N jack to N jack adaptor). Record this value.
2. Attach the patch cord to channel 1 as shown in Fig. 5-2.

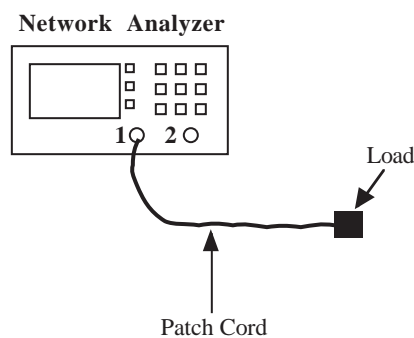

Figure 5-2: Block diagram for Section 5-6.1

3. Connect the short termination to the end of the patch cord. Place a marker at 800 MHz.
4. Add electrical delay until the response is point like.

- Press `[Scale]`
- Press the **Electrical Delay** softkey
- Rotate the knob on the network analyzer to the right until the response is point like. The amount of added delay is displayed on the network analyzer.

5. Record the added electrical delay. Print the display.
6. Set the electrical delay to 0 ns.

Note: After pressing the **Electrical Delay** softkey, you can enter **0** on the keypad and press `[Enter]` to set the electrical delay to 0 ns.

Measured Data

Copy the following chart into your lab book and fill in the measured data. If you are missing any data, please repeat the necessary parts of this experiment before proceeding to the analysis section.

Patch Cord Length = _____ (m)
 Added Electrical Delay = _____ (ns)

Analysis

1. Using Eq. 5.1, compute u_p for the patch cord using the experimentally determined electrical delay. Record the computed value of u_p .
2. Using $c = 3 \times 10^8$ (m/s), and the value of u_p computed in step 1, compute ϵ_r for the patch cord. Record the computed ϵ_r value.
3. Using the computed value of ϵ_r , compute β for this transmission line (assume $\mu = \mu_0$ and recall $f = 800$ MHz). Record the computed value of β .
4. Using $Z_0 = 50 \Omega$ and the relationship $\mu\epsilon = L'C'$, compute L' and C' of the transmission line. Record the computed values.

Questions

1. No measurements were made to compute R' and G' . Why?
2. What is the difference between a lossless line and a dispersionless (distortionless) line? Would this technique for measuring the line parameters work for a dispersionless line? Why or why not?
3. When performing the electrical delay measurements, why did we choose the short to terminate the cables instead of the matched load?
4. When computing u_p using the electrical delay technique, why did we have to use twice the length of the cable?

5-6.2 Lossy And Lossless Lines On The Smith Chart

In this experiment, you will use the network analyzer in the Smith Chart display format to show graphically how a wave propagates on a lossy and a lossless line.

At low frequencies, it is very difficult to make a lossy line. In this lab, you will be using a lossy line simulator (see Fig. 5-3) that has been made to demonstrate the response of a lossy line on a network analyzer. The lossy line simulator consists of a piece of wire soldered to a BNC connector and is housed in a metal box. Carbon absorber has been placed in the box to make the system more lossy. The wire acts essentially as a small antenna element. The impedance of the antenna element changes with frequency. In addition, the line radiates energy into the carbon absorber where the energy is converted to heat (a tiny amount). These two effects give the lossy line simulator the same characteristic response as a lossy line.



Figure 5-3: The lossy line simulator.

Setup

This experiment uses the network analyzer, patch cord, and the lossy line simulator.

Procedure

1. Connect the patch cord (lossless line) to channel 1 of the network analyzer. Print the resulting display.
2. Connect the lossy line simulator to the end of the patch cord using a N jack to BNC plug adaptor. Print the display.

Measured Data

There were no measurements made for this section, only the two printouts.

Analysis

1. Qualitatively comment on the display produced by the lossless patch cord. Why do you see a series of circles for your response? Are the circles relatively stationary in their position on the Smith Chart, that is, do they overlap each other or is there a 'spiral' pattern?
2. Qualitatively comment on the display produced by the lossy line simulator. Are the circles relatively stationary in their position on the Smith Chart, that is, do they overlap each other or is there a 'spiral' pattern? Why?

Questions

1. If the lossy transmission line was nearly infinite in length, where would the response spiral to? Why? Explain in terms of reflected power.

5-6.3 Impedance Measurements Using The Smith Chart

In this experiment, you will use the network analyzer in the Smith Chart display format to make load impedance measurements.

Setup

This experiment uses the network analyzer and various loads.

Setup the experiment:

- Connect the patch cord to channel 1 of the network analyzer as shown in Fig. 5-4.
- Configure the network analyzer.
 - Press **Preset**
 - Set the start frequency to 200 MHz
 - Set the stop frequency to 1.2 GHz
 - Set the network analyzer to measure reflection on channel 1
 - Set the display format to **Smith Chart**
 - Perform a 1 channel calibration
 - Save the instrument state

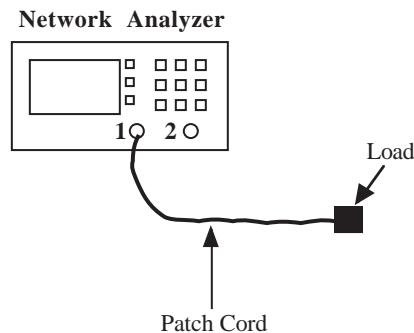

Figure 5-4: Setup for Section 5-6.3

Station	R (Ω)	C (pF)
1	22	39
2	100	10
3	10	39
4	68	15
5	39	1

Table 5-1: Resistor and capacitor values for the resistive, capacitive, series, and parallel loads.

Procedure

1. Connect the short termination to the end of the patch cord. Print the resulting display. Record the values of the impedances at 400 MHz, 600 MHz, 800 MHz, and 1.0 GHz. *To speed up the measurement process, you can place a marker at each of the frequencies by using the `Marker` function and using markers #1, #2, #3, and #4. The values of the markers will be displayed on the side of the display when you press `Marker`.*
2. Connect the open termination to the end of the patch cord. Print the display. Record the impedances at 400 MHz, 600 MHz, 800 MHz, and 1.0 GHz.
3. Connect the resistive termination to the end of the patch cord. Record the resistor value listed in Table 5-1. Print the display. Record the values of the impedances at 400 MHz, 600 MHz, 800 MHz, and 1.0 GHz.
4. Connect the capacitive termination to the end of the patch cord. Record the capacitor value listed in Table 5-1. Print the display. Record the values of the impedances at 400 MHz, 600 MHz, 800 MHz, and 1.0 GHz.
5. Connect the series termination to the end of the patch cord. Print the display. Record the values of the impedances at 400 MHz, 600 MHz, 800 MHz, and 1.0 GHz.
6. Connect the parallel termination to the end of the patch cord. Print the display. Record the values of the impedances at 400 MHz, 600 MHz, 800 MHz, and 1.0 GHz.

Measured Data

Copy the following charts into your lab book and fill in the measured data. If you are missing any data, please repeat the necessary parts of this experiment before proceeding to the analysis section.

Resistor = _____ (Ω)

Capacitor = _____ (pF)

Load Impedance

Load	400 MHz	600 MHz	800 MHz	1.0 GHz
Short				
Open				
Resistive				
Capacitive				
Series				
Parallel				

Analysis

- For each of the loads, compute the theoretical impedance* at each frequency (400 MHz, 600 MHz, 800 MHz, and 1.0 GHz). Assume that the length of the microstrip line is 2 cm and $\epsilon_r=7$. For the short and open terminations, assume 0.0 cm between the calibration point and the measurement point. Record the theoretical impedances.
- Enter each of the theoretical impedances on a Smith Chart. Use a different Smith Chart for each load, and represent each frequency using a different color. Draw the associated constant Γ circles.
- Compare the theoretical and measured values of the load impedance for each of the loads at each frequency. Comment on your results. If the measured and theoretical values do not agree, determine if the measured values make sense and explain. (Hint: what does the constant Γ circle represent?)
- For each of the loads, comment on the impedance response as a function of frequency (using the printouts). Is this what you expect to see? Why or Why not?

Questions

- Assuming that you did not have a short termination, explain using the Smith Chart how you could make a short circuit from an open circuit and a transmission line of appropriate length. How long does transmission line need to be? How frequency dependent is your solution?
- Based on your observations, is the microstrip line used in the resistive termination a wideband or a narrowband transmission line? Why? You may assume that all connectors and loads are ideal.

5-6.4 Impedance Matching Using A Single Stub Tuner

In this experiment, you will use the single stub tuner to match an unknown load to the patch cord. You will do it first experimentally, and then confirm analytically that you did achieve the best match possible.

*The capacitor and resistor values used in the series and parallel loads are the same as the values used in the resistive and capacitive loads.

Setup

This experiment uses the network analyzer, patch cord, single stub tuner, and the unknown load.

Setup the experiment:

- Attach the patch cord to channel 1 of the network analyzer.
- Set the start frequency to 450 MHz
- Set the stop frequency to 550 MHz

Procedure

1. Connect the unknown load to the patch cord. Print the display and record the value of the impedance at 500 MHz.
2. Insert the single-stub tuner between the patch cord and the unknown load as shown in Fig. 5-5. Record the distance between the load and the stub tuner.

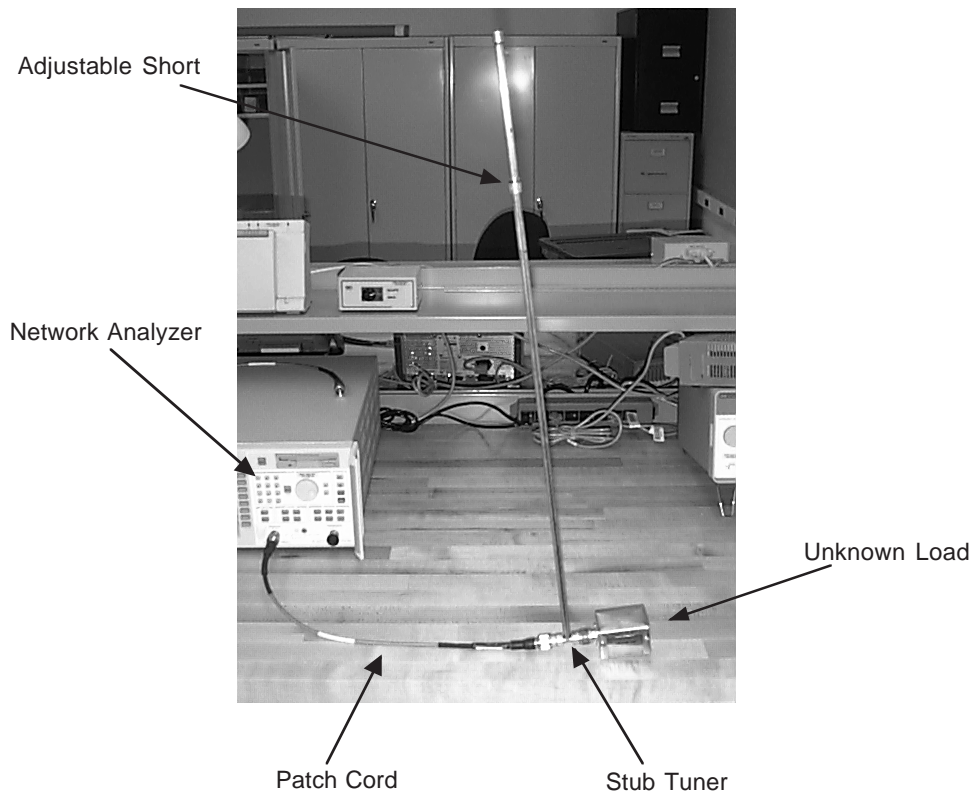

(a) Setup for Section 5-6.4 with the single stub tuner

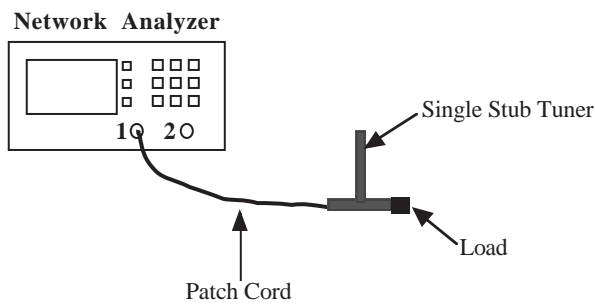

(b) Block diagram of setup

Figure 5-5: Setup for Section 5-6.4

- Adjust the position of the sliding short on the single stub tuner (see below) until the reflection coefficient is as close to that of a matched load ($\Gamma=0$) at 500 MHz as you can make it. The resulting stub length is measured from the base of the single stub tuner (the 'Tee') to the center of the sliding short. Record the resulting stub length. Print the resulting display and record the value of the resulting impedance at 500 MHz.

To adjust the length of the stub:

The length of the stub is adjusted by sliding the short up and down the line. Twist the short to the left to unlock it. Slide the position of the short to the bottom of the stub (near the connector). Slowly move the short up the stub until a match is achieved. To lock the short in place, twist the short to the right.

Measured Data

Copy the following chart into your lab book and fill in the measured data. If you are missing any data, please repeat the necessary parts of this experiment before proceeding to the analysis section.

Impedance before matching = _____ (Ω)
 Distance between load and stub tuner = _____ (cm)
 Length of stub = _____ (cm)
 Impedance after matching = _____ (Ω)

Note: All measurements made at 500 MHz

Analysis

1. In this experiment, you only had control of the length of the stub tuner, that is, the distance from the load was fixed. In general, if you were to design a matching system using a single stub tuner, you would be able to choose both the length of the stub and the distance from the load. Compute the theoretical value of the stub length by using the following procedure:
 - (a) Compute the normalized impedance z_l of the unknown load ($Z_0 = 50 \text{ } (\Omega)$).
 - (b) Enter this point on a Smith Chart. Label this point as **A**.
 - (c) Draw the constant VSWR (S) circle that passes through point **A**.
 - (d) Mark the point on the Smith Chart that corresponds to the normalized load admittance y_l . Label this point as **B**.
 - (e) Compute the recorded distance, d , between the load and the tuner in terms of wavelengths ($f = 500 \text{ MHz}$, $\epsilon_r = 1$). Record this value.
 - (f) Move a distance d toward the generator along the constant S circle. Remember that the Smith Chart repeats every $\frac{\lambda}{2}$, so express d as:

$$d = d' + n\frac{\lambda}{2}, n \text{ an integer}$$

and move a distance d' toward the generator. Label this point as **D**. Record the admittance y_d at point **D**.

- (g) Determine the needed normalized input admittance (y_s) of the stub to cancel out the imaginary part of y_d ($y_s = y_d^* = -\text{Im}\{y_d\}$). Mark this point on the Smith Chart. Label this point **E**.
 - (h) Mark the point on the Smith Chart that corresponds to the *admittance* of a short circuit. Label this point **F**.
 - (i) Determine the length of the stub in wavelengths by subtracting the position of **F** from **E** on the Wavelengths Toward Generator (WTG) scale. If the stub length is negative, add $\frac{\lambda}{2}$ to the length.
 - (j) Using the wavelength for a 500 MHz signal (assume free space ($\epsilon_r = 1$)), compute the physical length of the stub. Record the computed length of the stub. Is this length uniquely determined? Why or why not?
2. Compare the experimentally determined stub length to the theoretical stub length. Comment on the results.
 3. Compute the input impedance of the resulting load impedance and record this value. Compare the computed load impedance to the measured impedance after matching.

Questions

1. Were you able to achieve a perfect match with the single stub tuner? If not, why not?
2. Would a quarter wave transformer have achieved a better match for the unknown load? Why or why not?
3. Suggest a way that you could make use of both a single stub tuner and a quarter wave transformer to achieve a better match than with either of them alone.

5-7 LAB WRITE-UP

For each section of the lab, include the following items in your write-up:

- (a) Overview of the procedure and analysis
- (b) Measured data where asked for
- (c) Calculations (show your work!)
- (d) Any tables, printouts, and Smith Charts
- (e) Comparisons and comments on results
- (f) A summary paragraph describing what you learned from this lab