

Complementary Reciprocity Theorems For Two-Port Networks and Transmission Lines

C.T. Tai
Radiation Laboratory
Department of Electrical Engineering
and Computer Science
The University of Michigan
Ann Arbor, Michigan, 48109

Abstract

Two complementary reciprocity theorems have been formulated in this work, one for two-port passive networks and another for transmission lines. The theorems involve two networks or two identical sections of lines with different load impedances which must satisfy a complementary impedance condition relating to the characteristic impedances of the network or the characteristic impedance of a line.

1 Introduction

In electromagnetic theory there are two well-known reciprocity theorems, one due to Rayleigh and Carson and another due to Lorentz. Recently, we encountered a field problem which requires a new reciprocity theorem in order to provide for the answer. In this paper, we will present two simpler versions of that theorem; one applies to a pair of two-port networks and another to two identical sections of lines with different terminations.

2 Two-Port Networks

A two-port passive network can always be represented by a T-network as shown in Fig. 1 (a) with a shunt impedance Z_m and two series impedances Z_1 and Z_2 . The terminals at the left side of the network will be identified as the left terminals and the others as the right terminals. Now if the left terminals are driven by a voltage V_a and the right terminals are connected to a load impedance Z_R as shown in Fig. 1 (b), it is well known that the transfer function i_a/V_a of that circuit is equal to the transfer function i_b/V_b of the same circuit with the roles of V_a and i_a replaced by V_b and i_b as shown in Fig. 1 (c). This is the famous reciprocity theorem due to Rayleigh. It was later extended to field theory by Carson in the form

$$\iiint_{V_a} \bar{J}_a \cdot \bar{E}_b dV = \iiint_{V_b} \bar{J}_b \cdot \bar{E}_a dV \quad (1)$$

where \bar{J}_a and \bar{J}_b denote two current sources in volume V_a and V_b , respectively, which are responsive for producing the electric fields \bar{E}_a and \bar{E}_b in an identical environment containing isotropic media including the presence of electrically perfect conducting bodies in one of the media or in all media. When this theorem is applied to the networks shown in Fig. 1 (b) and (c), one can readily derive the reciprocity relationship

$$i_a/V_a = i_b/V_b \quad (2)$$

For the network under consideration, it is known that if a current source I_a is connected to the left terminals of that network and the right terminals are

still connected to a load impedance Z_R with a load current i_a , then the current transfer function i_a/I_a is not equal to the transfer function i_b/I_b when a current source I_b is connected to the right terminals in parallel with the same load impedance Z_R , and the left terminals are short-circuited resulting in a current i_b . In other words, for a single network,

$$i_a/I_a \neq i_b/I_b \quad (3)$$

or the current transfer function is non-reciprocal.

A reciprocity theorem for the current transfer function, however, can be formulated if we invoke two complementary networks as shown in Fig. 2 (a) and (b) where in network (b) the locations of Z_1 and Z_2 have been interchanged and another load impedance Z_b is connected to the right terminals which is, in general, different from Z_a , the load impedance in network (a). By a straightforward linear network analysis it can readily be shown that the currents in these two networks satisfy the reciprocity relationship

$$i_a/I_a = i_b/I_b \quad (4)$$

under the condition

$$Z_a Z_b = Z_{c1} Z_{c2} \quad (5)$$

where Z_{c1} and Z_{c2} denote, respectively, the characteristic impedances of the T-network looking from the opposite terminals. They are given by

$$Z_{c1} = \frac{1}{2} \left\{ (Z_1 - Z_2) + [(Z_1 + Z_2)(Z_1 + Z_2 + 4Z_m)]^{\frac{1}{2}} \right\} \quad (6)$$

$$Z_{c2} = \frac{1}{2} \left\{ (Z_2 - Z_1) + [(Z_1 + Z_2)(Z_1 + Z_2 + 4Z_m)]^{\frac{1}{2}} \right\} \quad (7)$$

hence

$$Z_{c1}Z_{c2} = Z_1Z_2 + (Z_1 + Z_2)Z_m \quad (8)$$

Equation (4) is designated as the complementary reciprocity theorem for the current transfer function, or $(I-i)_c$ theorem for short, in contrast to the $V-i$ reciprocity theorem of Rayleigh-Carson for a single network. Equation (5) is designated as the complementary impedance condition.

It can be shown that the product of the two characteristic impedances is also equal to $Z_{S1}Z_{O2}$ or $Z_{S2}Z_{O1}$, where Z_{S1}, Z_{S2} and Z_{O1}, Z_{O2} denote, respectively, the impedances looking into one pair of terminals of the T -network when the opposite terminals are either short-circuited or open-circuited.

For a symmetrical T -network, $Z_1 = Z_2$,

$$Z_{c1} = Z_{c2} = Z_c = [Z_1(Z_1 + 2Z_m)]^{\frac{1}{2}}, \quad (9)$$

and the physical configuration of the two complementary networks becomes identical, meanwhile, the impedance condition reduces to

$$Z_a Z_b = Z_c^2 \quad (10)$$

Only under the very special case corresponding to $Z_a = Z_b = Z_c$, that the two networks, including the load impedance, merge to one single entity. In

general, when network (a) and its load impedance Z_a are known or given we can construct the mirror image of that network to form network (b) and its load impedance is determined by (5). As an illustration, we let $Z_a = 0$, then $i_a = Z_m I_a / (Z_2 + Z_m)$. According to (5), we must have $Z_b \rightarrow \infty$, hence, the $(I-i)_c$ theorem yields $i_b = i_a I_b / I_a = Z_m I_b / (Z_2 + Z_m)$ which is certainly true by inspecting the circuitry of network (b). The $(I-i)_c$ theorem can be extended to cascade networks without much difficulty.

The above results can also be obtained by using a Π -network to represent a two-port network. The two complementary Π -networks then have the configurations as shown in Fig. 3 (a) and (b). In terms of the admittance functions y_1, y_2 and y_m , which are not equal to the reciprocals of Z_1, Z_2 , and Z_m , we find that the characteristic admittance of the network are given by

$$Y_{c1} = 1/Z_{c1} = \frac{1}{2} \left\{ y_1 - y_2 + [(y_1 + y_2)(y_1 + y_2 + 4y_m)]^{\frac{1}{2}} \right\} \quad (11)$$

$$Y_{c2} = 1/Z_{c2} = \frac{1}{2} \left\{ y_2 - y_1 + [(y_1 + y_2)(y_1 + y_2 + 4y_m)]^{\frac{1}{2}} \right\} \quad (12)$$

then

$$Y_{c1} Y_{c2} = 1/Z_{c1} Z_{c2} = y_1 y_2 + (y_1 + y_2) y_m \quad (13)$$

Equation (5) can then be changed to an equivalent form in terms of the admittance functions, namely,

$$Y_a Y_b = 1/Z_a Z_b = Y_{c1} Y_{c2} \quad (14)$$

These results, of course, can be obtained directly by applying the duality principle in network theory.

By taking a variation of (14) one finds $\delta Y_a = (Y_{c1} Y_{c2}) \delta Z_b$ or $\delta Z_b = (Z_{c1} Z_{c2}) \delta Y_a = Z_{c1} Z_{c2} \delta (1/Z_a)$ that means when the load admittance of circuit (a) is increased by δY_a , the load impedance of circuit (b) must be increased by an amount such that the two increments also satisfy the complementary impedance condition.

It may be of some interest to remark that the two networks shown in Fig. 2 (a) and (b) within the boxes were used by Guillemin [1] to define two iterative impedances when they are connected in cascade. It can be shown that the product of the two iterative impedances is equal to the product of the two characteristic impedances of the individual network given by (8). Similar relation holds for the product of the iterative admittances and that of the characteristic admittances. For a symmetrical network ($Z_1 = Z_2$), we have only one characteristic impedance function and one iterative impedance function which are equal to each other.

3 Transmission Lines

The complementary reciprocity theorem for two identical sections of transmission lines of length 'd' extending from $x = 0$ to d and with line constants L and C is based on two models shown in Fig 4 (a) and (b). Line (a) is terminated at its two ends by Z_a and Z'_a and Line (b) by Z_b and Z'_b at the corresponding ends. The lines are excited by two distributed current sources $K_a(x)$ and $K_b(x)$

are solutions of the equations

$$\frac{dv_a(x)}{dx} = i\omega L i_a(x) \quad (15)$$

$$\frac{di_a(x)}{dx} = i\omega C v_a(x) + K_a(x) \quad (16)$$

and two similar equations for $v_b(x)$, $i_b(x)$, and $K_b(x)$. The boundary conditions are

$$v_a(0) = Z_a i_a(0), \quad v_a(d) = Z'_a i_a(d) \quad (17)$$

$$v_b(0) = Z_b i_b(0), \quad v_b(d) = Z'_b i_b(d) \quad (18)$$

By using the equations for the line voltages and currents it can be shown that

$$\begin{aligned} \frac{d}{dx} [i_a(x)i_b(x) - v_a(x)v_b(x)/Z_c^2] \\ = K_a(x)i_b(x) + K_b(x)i_a(x) \end{aligned} \quad (19)$$

where $Z_c = (L/C)^{1/2}$, denoting the characteristic impedance of the lines. An integration of (19) from $x = 0$ to d yields

$$\begin{aligned} \int_0^d [K_a(x)i_b(x) + K_b(x)i_a(x)] dx \\ = [i_a(x)i_b(x) - v_a(x)v_b(x)/Z_c^2]_0^d \end{aligned} \quad (20)$$

In view of the boundary conditions stated by (17), and (18), we can put (20) in the form

$$\begin{aligned} \int_0^d [K_a(x)i_b(x) + K_b(x)i_a(x)] dx \\ = i_a(d)i_b(d) [1 - Z'_a Z'_b / Z_c^2] \\ - i_a(0)i_b(0) [1 - Z_a Z_b / Z_c^2] \end{aligned} \quad (21)$$

Now if we impose the conditions

$$Z_a Z_b = Z_c^2 \quad (22)$$

and

$$Z'_a Z'_b = Z_c^2 \quad (23)$$

simultaneously, (21) reduces to

$$(24) \quad \int_0^d [K_a(x)i_b(x) + K_b(x)i_a(x)] dx = 0$$

The above formula is a statement of the complementary reciprocity theorem for the two lines, or $(K-i)_c$ theorem for short, under the condition that their terminal impedances satisfy the complementary impedance conditions stated by (22) and (23). If Z_c , Z_a , and Z'_a are given or known, these two equations can be used to determine Z_b and Z'_b .

Some special cases should be pointed out. When $d \rightarrow \infty$, the two sections of line become semi-infinitely long. The case is also equivalent to

$$Z'_a = Z'_b = Z_c \quad (25)$$

When Line (a) is short-circuited at both ends ($Z_a = Z'_a = 0$) then Line (b) must be open-circuited at both ends ($Z_b \rightarrow \infty$, $Z'_b \rightarrow \infty$). Other combinations can be easily visualized. These conditions demonstrated very clearly the significance of the complementary status of the two lines. The two complementary lines under discussion are quite different from the two circuits considered by Van Bladel [2] in his analysis of the symmetrical property of some scattering matrices in

the theory of waveguides. In contrast, our complementary reciprocity theorem can be used to investigate the symmetrical property of the scalar Green functions relating to the current on a transmission line without finding the explicit expressions of the Green functions.

When the current sources on the lines are localized we can write

$$K_a(x) = I_a(x_a) \delta(x - x_a) \quad (26)$$

$$K_b(x) = I_b(x_b) \delta(x - x_b) \quad (27)$$

where $\delta(x - x_a)$ denotes a delta function defined at $x = x_a$ and similarly for $\delta(x - x_b)$. Substituting these two expressions into (24) we obtain the circuit relation

$$I_a(x_a) i_b(x_a) = -I_b(x_b) i_a(x_b) \quad (28)$$

The circuit relation for a single section of line terminated by any two load impedances at the ends, derivable from an application of the Rayleigh-Carson reciprocity theorem, would be

$$I_a(x_a) v_b(x_a) = I_b(x_b) v_a(x_b) \quad (29)$$

where $v_a(x_a)$ and $v_b(x_b)$ denote two line voltages measured across the lines. This shows the difference of the two reciprocity theorems both in the context and in the formulations.

As an example for the application of the complementary reciprocity theorem stated by (28), let us consider two semi-infinite lines or with $Z'_a = Z'_b = Z_c$ and

Line (a) is short-circuited at $x = 0$ ($Z_a = 0$) that means Line (b) must be open-circuited at $x = 0$ ($Z_b = \infty$). A localized current source with unit amplitude is now applied to Line (a) at x' . The solution for $i_a(x)$ obtainable from the theory of transmission lines [3] is

$$i_a(x) = \begin{cases} -i \sin kx' e^{ikx}, & x > x' \\ -e^{ikx'} \cos kx, & x < x' \end{cases} \quad (30)$$

By means of (28), we find that if a unit current source is applied to Line (b) at x , the current at x' would be

$$i_b(x') = \begin{cases} i \sin kx' e^{ikx}, & x > x' \\ e^{ikx'} \cos kx, & x < x' \end{cases} \quad (31)$$

By interchanging x and x' in (31), we obtain the solution for $i_b(x)$ when a unit current source is applied to that line at x' , namely,

$$i_b(x) = \begin{cases} ie^{ikx'} \sin kx, & x < x' \\ \cos kx' e^{ikx}, & x > x' \end{cases} \quad (32)$$

In other words, it is not necessary to solve $i_b(x)$ as a separate problem once the solution for the complementary problem is known or vice versa. Both (30) and (32) also show clearly that the current transfer function for a single line is non-reciprocal.

The complementary reciprocity theorems presented in this paper represent the circuit version and the one-dimensional version of a more complex theorem for a three-dimensional electromagnetic field with multiple layers of isotropic media backed by a conducting body. In appearance, the theorem has a rather

simple form, namely,

$$\iiint_{V_A} \bar{J}_A \cdot \bar{H}_B dV = \iiint_{V_B} \bar{J}_B \cdot \bar{H}_A dV \quad (33)$$

where \bar{J}_A and \bar{J}_B denote two electric current density functions in two complementary models like \bar{K}_a and \bar{K}_b in the transmission line theory, occupying, respectively, volume V_A and V_B . \bar{H}_A and \bar{H}_B denote the magnetic fields produced by these two currents in two complementary environments, corresponding to i_a and i_b in the transmission line models. The proof of (33), however, is much more involved. The work will be reported elsewhere together with an application of that theorem to a boundary-value problem in electromagnetics. A part of the present paper is based on a technical report on the complementary reciprocity theorems in electromagnetic theory [4], available upon request.

In conclusion, it should be emphasized that the complementary reciprocity theorem for the two-port networks and that for the transmission lines are quite distinct from the Rayleigh-Carson theorem. The latter involves only a single network or a single section of line while the new theorems apply to two complementary circuits and two identical sections of line with different load impedances which are related to each other in terms of the characteristic impedances of the structures.

The author is indebted to Prof. Alan B. Macnee for calling attention to the identity between the products of the iterative impedances and that of the characteristic impedances of a two-port unsymmetric network. He is most grateful to Ms. Bonnie Kidd for the preparation of this manuscript.

References

- [1] E.A. Guillemin, Communication Networks, Vol. II, John Wiley, New York, NY, 1935, p. 166.
- [2] J. van Bladel, Electromagnetic Fields, McGraw-Hill, New York, NY, 1964, p. 436.
- [3] C.T. Tai, Dyadic Green's Functions in Electromagnetic Theory, Intext Publishers, Scranton, PA, 1971, Chapter 3.
- [4] C. T. Tai, 'Complementary reciprocity theorems in electromagnetic theory,' Technical Report RL-869, Radiation Laboratory, Department of Electrical Engineering and Computer Science, The University of Michigan, Ann Arbor, MI, September 1991.

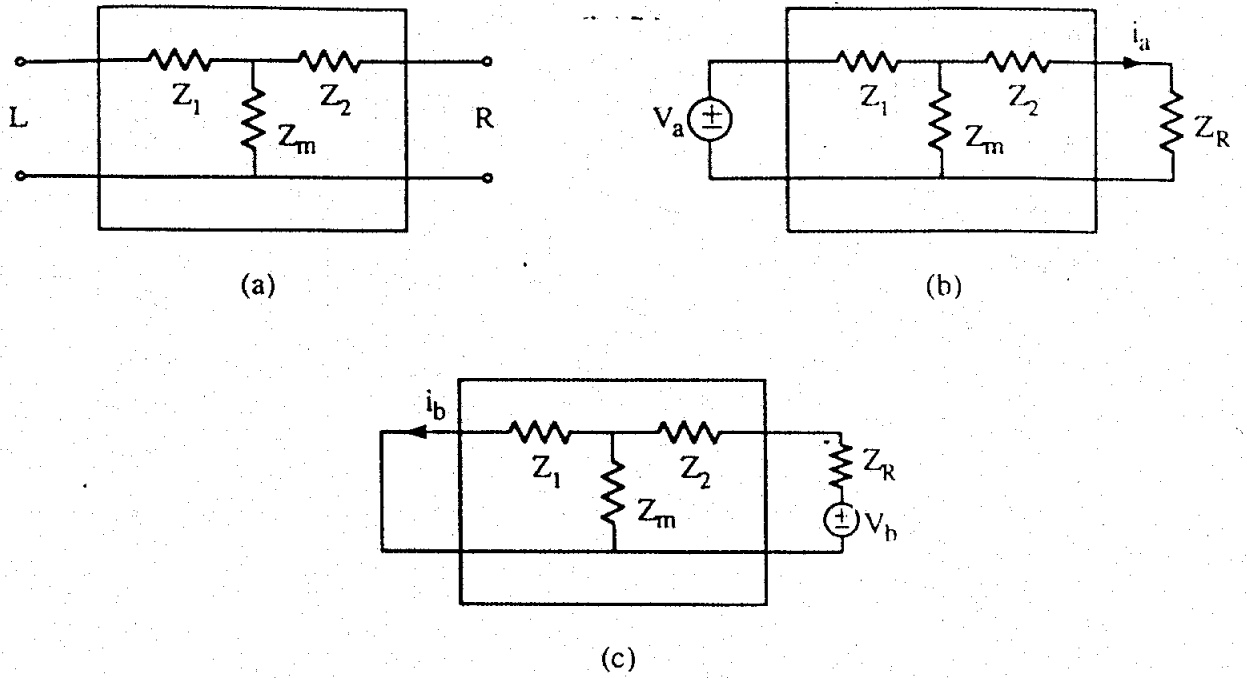

Fig. 1. A two-port T-network with two different driving conditions.

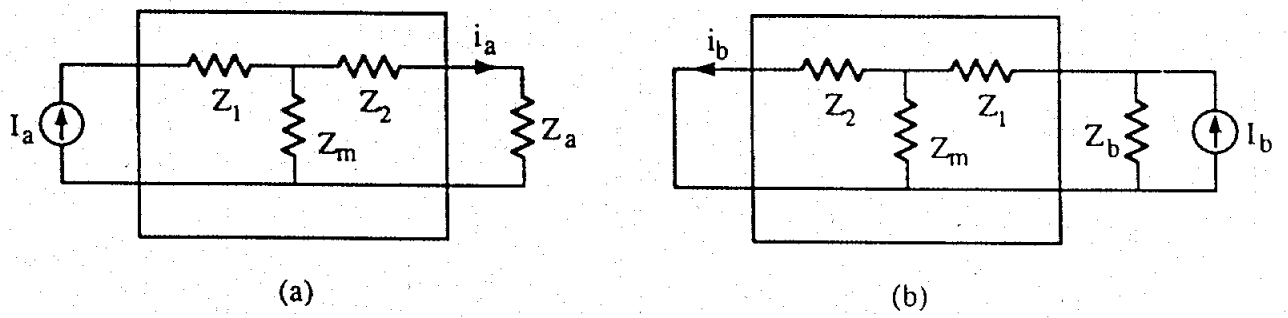

Fig. 2. Two complementary T-networks.



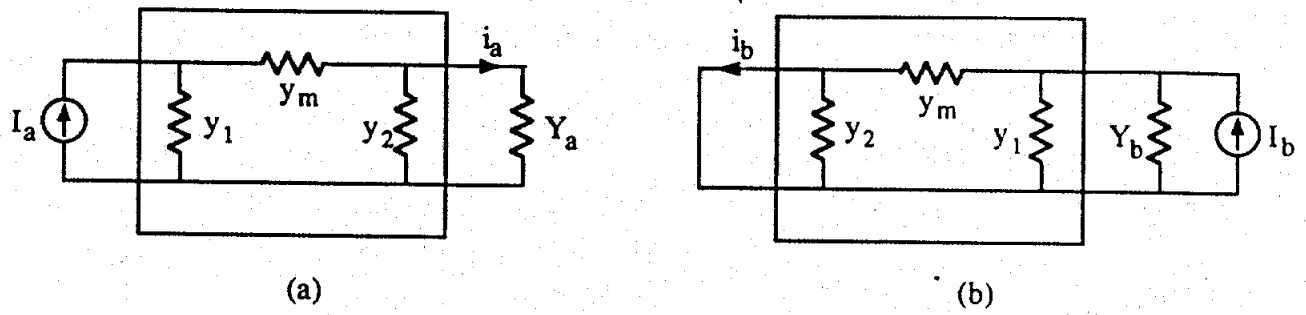
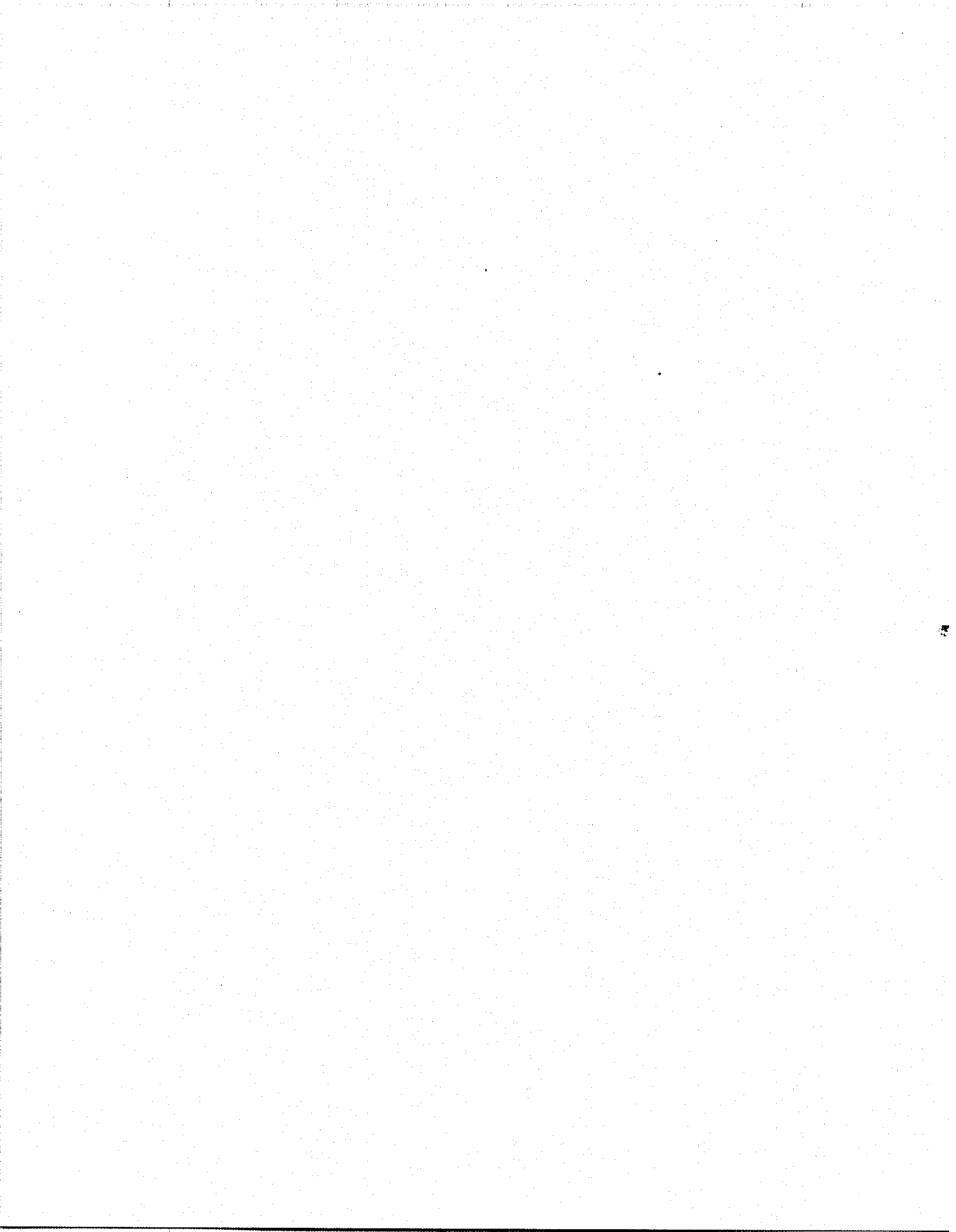
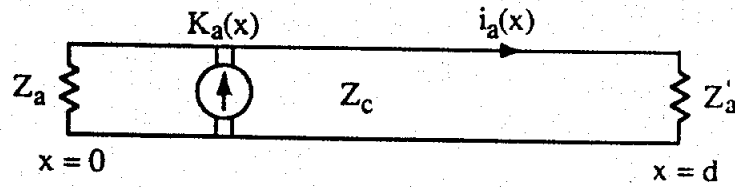
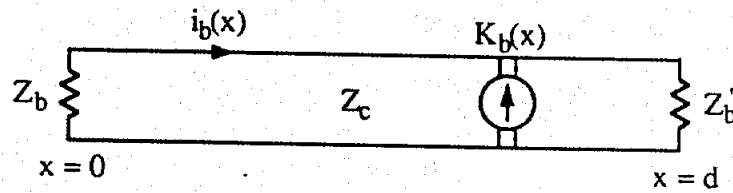

Fig. 3. Two complementary Π -networks.





(a) A section of transmission line terminated by two load impedances Z_a and Z'_a .



(b) An identical section of line terminated by two load impedances Z_b and Z'_b .

Fig. 4. Two sections of line with the complementary impedance conditions $Z_a Z_b = Z_c^2$, $Z'_a Z'_b = Z_c^2$.

