

# Short Papers

## A 75 GHz to 115 GHz Quasi-Optical Amplifier

Thomas P. Budka, Michael W. Trippe,  
Sander Weinreb, and Gabriel M. Rebeiz

**Abstract**—A wideband quasi-optical amplifier employing two pyramidal back-to-back horns has been developed. Using a four-stage W-band low noise amplifier (LNA) designed and fabricated by Martin Marietta Laboratories, the quasi-optical amplifier gives a system gain greater than 11 dB from 86 GHz to 113 GHz without any low frequency oscillations. A peak system gain of 15.5 dB is measured at 102 GHz, and the measured noise figure of the system is 7.4 dB at 94 GHz. The quasi-optical amplifier design maintains the same polarization of the received and transmitted signal, provides better than  $-40$  dB isolation, and can be fabricated monolithically at millimeter-wave frequencies.

### I. INTRODUCTION

Recent advances in transistor technology at Martin Marietta Laboratories have led to the development of a four-stage W-band noise amplifier (LNA) using pseudomorphic InGaAs modulation-doped field effect transistors (MODFET's). These amplifiers have demonstrated gains up to 23 dB in a waveguide environment [1]. The amplifiers typically employ a waveguide-to-microstrip or waveguide-to-coplanar waveguide transition [1], and the waveguide fixture is expensive to build at frequencies higher than 100 GHz. For array applications it is advantageous to incorporate these amplifiers directly within a radiating structure that can be fabricated monolithically. This approach has been pursued at lower frequencies in [2], [3]. In both techniques, the quasi-optical amplifiers employ polarization diplexing along with a differential amplifier stage. In this note, a new quasi-optical amplifier design based on the integrated horn structure [4] is presented. There is no need for tuning polarizers and therefore this design allows a wide operating bandwidth. The design maintains the same polarization and is compatible with high gain monolithic millimeter wave amplifiers. It is possible to incorporate this design in an array on a wafer-scale level for quasi-optical power combining applications at millimeter wave frequencies.

### II. DESIGN

The quasi-optical amplifier consists of two back-to-back pyramidal horns each with openings of  $1.35\lambda_0 \times 1.35\lambda_0$  at the design frequency of 94 GHz. A  $4.25 \text{ mm} \times 1.25 \text{ mm}$  Martin Marietta Laboratories LNA chip is placed approximately  $\lambda_0/2$  above the apex of each pyramidal horn (Fig. 1(a)). Two back-to-back pyramidal horns were fabricated by anisotropically etching  $\langle 110 \rangle$  silicon wafers from opposite sides and stacking eight  $385 \mu\text{m}$ -thick horn sections and one  $200 \mu\text{m}$  cavity spacing section. The LNA is hybrid mounted in the etched cavity connecting the two integrated horns (Fig. 1(b)). The cavity is  $3.0 \text{ mm}$  wide by  $200 \mu\text{m}$  high. The thickness of the LNA GaAs substrate is  $100 \mu\text{m}$ . The sidewalls of the horns and the sides of the cavity were metallized with  $0.7 \mu\text{m}$  of gold through angle evaporation.

Manuscript received February 9, 1993; revised August 5, 1993.

T. P. Budka and G. M. Rebeiz are with NASA/Center for Space Terahertz Technology, University of Michigan, Ann Arbor, MI 48109-2122.

M. W. Trippe and S. Weinreb are with Martin Marietta Laboratories, Baltimore, MD 21227.

IEEE Log Number 9216808.

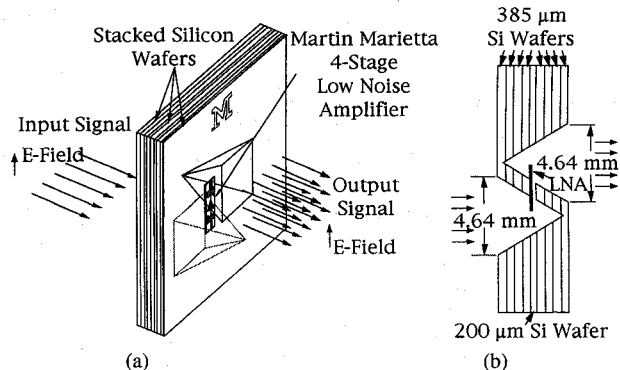

Fig. 1. Quasi-optical amplifier consisting of Martin Marietta Laboratories' low noise amplifier between two back-to-back pyramidal horns. A plane wave input signal is amplified and repeated on the opposite side with the same polarization. (a) Isogonal view. (b) Side view.

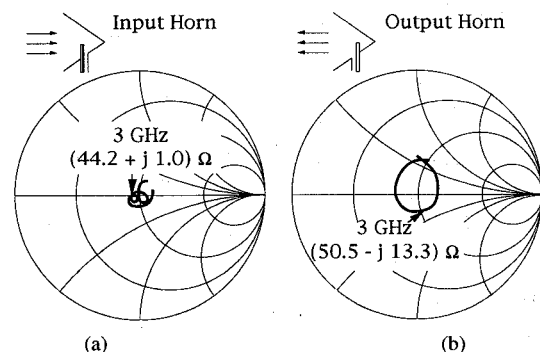

Fig. 2. Input impedance of a scaled monopole probe measured from 2.75 GHz to 3.25 GHz (equivalent to 86.5 GHz to 102 GHz) inside the (a) input pyramidal horn and (b) output pyramidal horn.

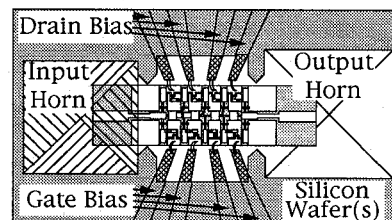

Fig. 3. Martin Marietta Laboratories' low noise amplifier (LNA) chip placed in a cavity between two horn openings. The LNA chip dimensions are  $4.25 \text{ mm}$  by  $1.25 \text{ mm}$ .

The position of the chip within the horn cavity is chosen using a 3 GHz (equivalent to 94 GHz) microwave scale model for a probe of length  $600 \mu\text{m}$  and width of  $190 \mu\text{m}$  on a  $100 \mu\text{m}$  thick GaAs substrate (at 94 GHz). An input match ( $S_{11}$ ) better than  $-20$  dB from 2.75 GHz to 3.25 GHz (equivalent to 86.5 GHz to 102 GHz) is measured with the probe facing the interior of the input horn (Fig. 2(a)). An input match better than  $-10$  dB is measured with the probe facing out of the output horn over the same frequency range (Fig. 2(b)). The probe radiates preferentially into the dielectric side, thereby resulting in a better match for the input horn.

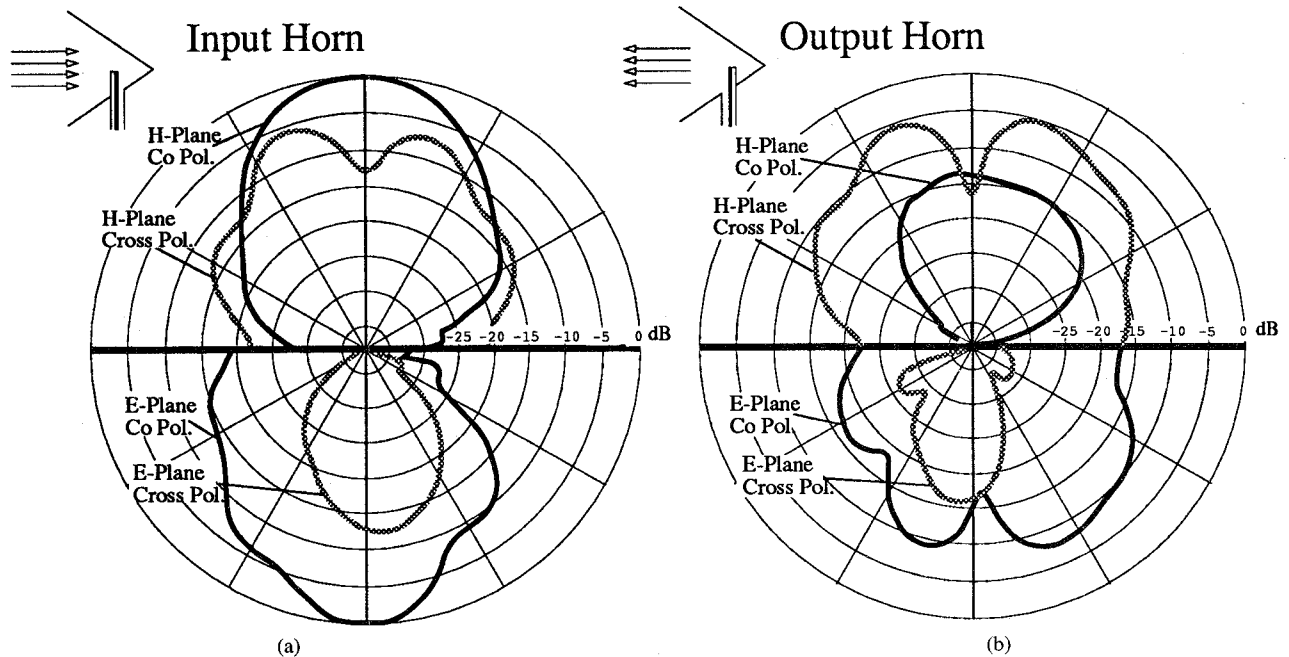

Fig. 4. Quasi-optical amplifier 3 GHz microwave model (equivalent to 94 GHz) antenna patterns. (a) Antenna patterns with monopole facing the interior of the horn. (b) Antenna patterns with monopole facing the exterior of the horn.

The LNA is mounted on a silicon wafer containing the bias lines, bias resistors and bypass capacitors (Fig. 3). The four gates were biased at 0.25 V. The drains were biased separately and optimized for maximum gain. The bias voltages for the drains, from input to output, were 4.5 V, 3.8 V, 3.5 V, and 3.5 V, respectively. The total source-to-drain current for all four MODFET's is 24 mA. The source is grounded on the back side of the LNA chip along the receiving horn sidewall using silver epoxy and 0.7 mil gold ribbon.

### III. MEASUREMENTS

Patterns taken from a 3 GHz microwave model show a very high cross-polarization level of both the input and output integrated horns (Fig. 4). This is attributed to the short length and large width of the waveguide-to-CPW probe. Since the probe dimensions of the LNA were fixed, we were not able to decrease the cross-polarization level. We recommend that a longer narrower probe be used for future quasi-optical amplifier applications which will result in reduced cross-polarization levels [6]. The short monopole probe also results in an asymmetry in the E-plane copolarization pattern. No pattern measurements were performed at other frequencies, but the same behavior is expected over the 2.75–3.25 GHz band (equivalent to 86.5 GHz to 102 GHz). Notice that the input pattern is better than the output pattern because the monopole probe radiates preferentially into the dielectric side of the substrate [7].

The gain of the quasi-optical amplifier structure is measured in a plane-wave experiment similar to [2]. First, the system is calibrated without the quasi-optical amplifier present. The power received during calibration,  $P_c$ , is determined from Frii's transmission formula

$$P_c = P_t \left( \frac{\lambda^2 G_t G_r}{(4\pi(2r))^2} \right) \quad (1)$$

where  $2r$  is the distance between the transmitting and receiving horns,  $P_t$  is the transmitted power,  $G_t$  is the gain of the transmitting antenna (a WR-10 pyramidal horn), and  $G_r$  is the gain of the receiving antenna (a WR-10 pyramidal horn). Next, the power received,  $P_r$ ,

with the quasi-optical amplifier in place is given by

$$P_r = P_t \left( \frac{G_t A_i^{\text{eff}}}{4\pi r^2} \right) G \left( \frac{G_r A_o^{\text{eff}}}{4\pi r^2} \right) \quad (2)$$

where  $G$  is the gain of the LNA,  $A_i^{\text{eff}}$  is the effective aperture area of the *input* horn,  $A_o^{\text{eff}}$  is the effective aperture area of the *output* horn and  $r$  is the distance between the transmitting/receiving horn and the quasi-optical amplifier. Since the effective apertures of the input and output integrated horns are not known accurately, the aperture efficiencies are separated from the physical area of the input and output integrated horns

$$P_r = P_t \left( \frac{G_t \epsilon_i^{\text{eff}} A_{\text{phys.}}}{4\pi r^2} \right) G \left( \frac{G_r \epsilon_o^{\text{eff}} A_{\text{phys.}}}{4\pi r^2} \right) \quad (3)$$

where  $A_{\text{phys.}}$  is the physical area of the input and output horns,  $\epsilon_i^{\text{eff}}$  is the effective aperture efficiency of the *input* horn, and  $\epsilon_o^{\text{eff}}$  is the effective aperture efficiency of the *output* horn. The gain of the quasi-optical system,  $G_{SYS}$ , is then found by dividing (1) by (3) and solving for  $G \epsilon_i^{\text{eff}} \epsilon_o^{\text{eff}}$ ,

$$G_{SYS} = G \epsilon_i^{\text{eff}} \epsilon_o^{\text{eff}} = \left( \frac{P_r}{P_c} \right) \left( \frac{\lambda r}{2A_{\text{phys.}}} \right)^2. \quad (4)$$

The system gain is measured over the frequency range of 75 GHz to 115 GHz. The gain of the quasi-optical amplifier,  $G_{SYS}$ , is greater than 11 dB from 85 GHz to 113 GHz and greater than 3 dB gain from 75 GHz to 115 GHz (Fig. 5). No oscillations were found on the bias lines or in free space and the isolation is better than -40 dB when the bias is removed. The variations of the gain curve versus frequency are potentially due to the changes in the antenna pattern, cross-polarization level, input impedance, and reference power calibration. From microwave pattern modeling, we expect the co-polarized aperture efficiency of each horn to be below 60% at 94 GHz. Thus the lower limit of the gain of the amplifier chip itself would be at least 4 dB above the curve in Fig. 4. Although the exact gain of the LNA is not known, histograms of the gains of 44 different LNA's fabricated at the same time suggest a mean LNA

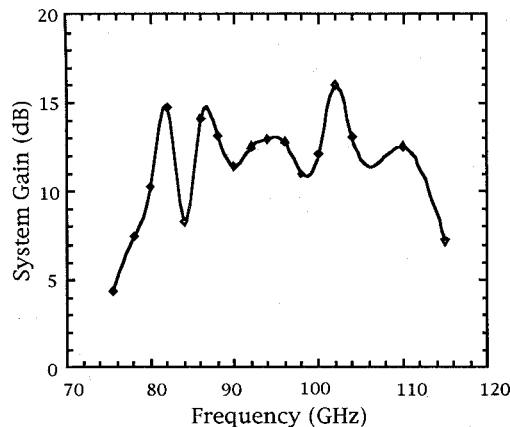

Fig. 5. Quasi-optical amplifier system gain versus frequency. The system gain includes loss due to input and output horn aperture efficiency (see text for more detail).

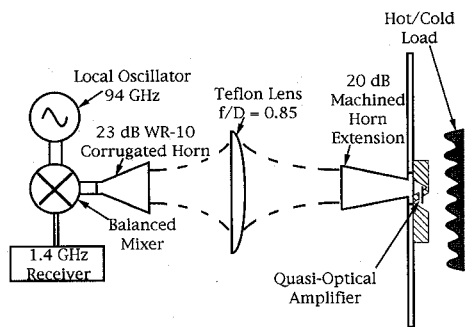

Fig. 6. Noise figure experiment using an LO frequency of 94 GHz and an IF of 1.4 GHz.

gain of 16.3 dB around 90 GHz and a standard deviation of 3.2 dB. This value corresponds closely with the measured system gains of 12.9 dB at 94 GHz and 15.5 dB at 102 GHz. If the effective aperture efficiencies were deembedded from the gain calculation, the gain would increase by more than 4 dB to 16.9 dB at 94 GHz.

Fig. 6 displays the experiment for measuring the noise figure of the quasi-optical amplifier. The IF chain gain and input noise temperature is measured to be 97.0 dB and 55.3 K, respectively, at 94 GHz. The conversion loss of the balanced mixer is measured to be 4.6 dB with a mixer input noise temperature of 821 K. The loss of the teflon lens ( $f/D = 0.85$ ) is determined to be 0.30 dB. Next, we measure the noise figure of the quasi-optical amplifier to be 7.4 dB at 94 GHz using standard hot/cold load techniques. The absorber is placed very close to the input horn antenna to ensure that the whole input pattern is coupled to the hot/cold load. This value matches with an expected 7–8 dB noise figure from these specific LNA's. New LNA's from Martin Marietta Laboratories that have 23 dB gain and 4.3 dB noise figure [1] would greatly improve the performance of the quasi-optical amplifier.

#### IV. CONCLUSIONS

In this note, we report a single element quasi-optical amplifier that is based on an integrated horn antenna using a LNA originally designed for operation within waveguide. Using the waveguide-to-CPW probe as the radiating element for the structure, a peak system

gain of 15.5 dB at 102 GHz is measured and higher than 11 dB system gain is measured over a 27% bandwidth. The quasi-optical horn antenna can be designed to result in a much lower cross-polarization level using a long monopole probe and to couple efficiently to a Gaussian beam system using an integrated horn extension [4]. Unlike other amplifiers, this quasi-optical amplifier maintains the same polarization of the incoming and outgoing signal. The absence of tuning polarizers allow a wider operating bandwidth for this design.

#### ACKNOWLEDGMENT

Research supported in part by NASA/Center for Space Terahertz Technology, United States Army Research Office under contract number DAAL03-91-G-0116 and in part by Martin Marietta Laboratories. The authors appreciate the help of Dr. Thomas Burke, United States Army Research Laboratory, and Dr. James Mink, United States Army Research Office for their support of this project.

#### REFERENCES

- [1] M. W. Trippe, S. Weinreb, S. W. Duncan, A. Eskandarian, B. A. Golja, *et al.*, "mm-Wave MIMIC receiver components," *IEEE 1991 Monolithic Circuits Symp. Dig.*, 1991, pp. 51–54.
- [2] M. Kim, J. J. Rosenberg, R. P. Smith, R. M. Weikle II, J. B. Hacker, *et al.*, "A grid amplifier," *IEEE Microwave Guided Wave Lett.* vol. 1, pp. 322–324, Nov. 1991.
- [3] C. Chi and G. M. Rebeiz, "A quasi-optical amplifier," *IEEE Microwave and Guided Wave Letters* to appear.
- [4] G. V. Eleftheriades, W. A. Ali-Ahmad, L. P. B. Katehi, and G. M. Rebeiz, "Millimeter-wave integrated horn antennas: Part I: Theory and Part II: Experiment," *IEEE Trans. Antenna Propagat.*, vol. 39, pp. 1575–1586, Nov. 1991.
- [5] G. V. Eleftheriades and G. M. Rebeiz, "Design and analysis of quasi-integrated horn antennas for millimeter and submillimeter-wave applications," *IEEE Trans. Microwave Theory Tech.*,
- [6] G. V. Eleftheriades, "Design and analysis of quasi-integrated horn antennas for millimeter and submillimeter-wave applications," Ph.D. dissertation, Univ. Michigan, Ann Arbor, 1993.
- [7] D. B. Rutledge, D. P. Neikirk, and D. P. Kasilingam, "Integrated circuit antennas," in K. J. Button, Ed. *Infrared and Millimeter-Waves*, vol. 10. New York: Academic Press, 1983, pp. 1–90.

### Infrared Fiberoptic Temperature Control of the Heating Process in a Microwave Oven

Edward Belotserkovsky, Ofer Shenfeld and Abraham Katzir

**Abstract**—An infrared (IR) fiberoptic temperature sensor was used to monitor of non-uniform heating of biological samples. The developed system allows the monitoring of temperature with an accuracy of  $\pm 0.5^\circ\text{C}$  and can be very useful for medical, industrial and domestic applications.

#### I. INTRODUCTION

Microwave (MW) heating has become very useful in medical applications such as hyperthermia [1] and treatment of hypothermia [2]. The MW devices can also be very useful when fast volume heating is necessary. However, the use of conventional electric

Manuscript received December 9, 1992; revised July 26, 1993.

The authors are with the Raymond and Beverly Sackler Faculty of Exact Sciences, School of Physics and Astronomy, Tel-Aviv University, Tel-Aviv, 69978, Israel.

IEEE Log Number 9216820.