

Simultaneous Downconversion of Multiple Bandpass Signals

Aditya Mahajan Manu Agarwal

April 15, 2003

Acknowledgment

Our heartfelt gratitude goes to our B.Tech. Project guide Dr. A K Chaturvedi, whose unceasing support and encouragement has been the driving force for the completion of this project for more than two semesters now, and shall remain the driving force for all our future endeavours. His great regard for innovation but uncompromising stance on thoroughness in research acted as the founding pillars of this project.

We would also like to thank the members of the *Mobile Communications Laboratory*, IIT Kanpur for their help and support during this project, and especially Mr. P.R. Sahu for helping us with the PC's. Without their help the simulation results compiled in this report would not have been possible.

Finally, we would like to thank our parents and God almighty for making us what we are today. For being loving, for being patient and for being there for us always.

Aditya Mahajan
Manu Agarwal

Abstract

In the present cellular networks, the ability to demodulate more than one channel at the same time has many applications. In this project we propose a novel receiver to simultaneously demodulate multiple frequency multiplexed channels. Instead of multiplying the incoming signal with a single carrier frequency which brings down any one channel to baseband, we multiply the received signal with a especially designed *down-conversion* function which brings all the message signals simultaneously to the baseband. Then they are sampled using a single ADC, separated in the digital domain by merely deinterleaving the samples into various channels and demodulated. The receiver gives the same performance as conventional schemes and is expected to have low hardware and power.

Contents

1. Introduction	1
2. Proposed Receiver	3
2.1. Transmitter Model	3
2.2. Proposed Receiver	5
2.3. Down-Conversion Function	6
2.3.1. Properties	6
2.3.2. Design	7
2.4. Bandpass Filter	11
2.5. Minimum Frequency Separation	12
2.6. Low Pass Filter Bandwidth	14
3. Performance Analysis	16
3.1. Auto-Correlation function of $s(t)$	16
3.2. Performance of the Equivalent Receiver	17
3.3. Performance of Proposed Receiver	18
4. Simulation Results	19
4.1. Carrier Frequency Separation	19
4.2. Bandpass Filter Bandwidth	19
4.3. Number of Channels	22
4.4. Analyzing spectrum in GSM	23
5. Hardware Realization	24
6. Comparison	26
6.1. Performance Comparison	26
6.2. Comparison with bandpass sampling	26
6.3. Comparison with Conventional Parallel receiver	27
7. Conclusion	28
A. Simulation Details	29
A.1. Transmitter	29
A.2. Channel	29
A.3. Receiver	29

Contents

A.4. Number of bits to be Simulated	31
A.5. Minimum Frequency Separation	31

List of Figures

2.1. Transmitter for one channel	3
2.2. Proposed Receiver	4
2.3. Conventional Parallel Receivers	6
2.4. FFT of complete $d(t)$	9
2.5. Down-conversion function waveforms	10
2.6. Bandpass filter	11
2.7. Fourier Transform of the down-converted signal for different bandwidths of BPF, a) for $B < \frac{R_s}{N}$, b) for $B = \frac{R_s}{N}$, c) for $B = 2\frac{R_s}{N} - W$	12
2.8. $S(f)$ in frequency domain	14
2.9. Fourier Transform of LPF output and DTFT of sampled data for $N = 3$ case.	15
2.10. Aliasing effect in $N = 4$ (<i>even</i>) case.	15
3.1. Equivalent Receiver	16
4.1. Interference in channel 1 due to signal in channel 0. $f_{c,0} = 600$ MHz and $f_{c,1}$ is swept over 520 MHz to 680 MHz	19
4.2. Performance for different bandwidths of the BPF for $N = 2$	21
4.3. Performance for different values of N	23
5.1. Generating down-conversion function from periodic sincs.	24
5.2. Generating down-conversion function from cosines.	25

1. Introduction

In cellular telephony, the handset's ability to demodulate more than one channel can have many applications. The user may want to use the same handset for taking more than one service from the same or different service providers. This requires that the handset is able to demodulate more than one channel at the same instant of time, or in other words has the ability to simultaneously demodulate different channels. This feature can also be used to increase the data rate from the base station to the handset. The base station can send parallel streams of data in different channels and the handset can demodulate them simultaneously and combine the different streams. Further, there are many situations in which the handset has to scan the spectrum to find if a signal is present or not. One such example is a cellular scenario like *GSM*. On starting up, the mobile handset has to scan the spectrum for locating ARFCNs. It does this in a sequential manner. Using simultaneous demodulation, we can reduce this time considerably.

Thus there is a need for receivers that can simultaneously demodulate different channels. Bandpass Sampling has been proposed for this [1]. It requires sharp bandpass filters and an appropriate choice of sampling frequency, which can be difficult to choose. Another very commonly used method is *wideband* receiver [5] which is used when all the bands are adjacent. The complete band is brought down to baseband and digitized, with all other operations taking place on the digital signal. This scheme has a serious limitation that it cannot be used when the signals are not adjacent. Finally simultaneous demodulation can also be done in parallel by using a separate receiver for each channel.

For handsets, cost and power are very serious concerns. They determine the choice of the receiver that a handset would use. In this project, we propose a new design for simultaneous multi-channel digital receiver, targeting the handset rather than the base station.

The conventional digital receiver broadly works as follows. The incoming signal is frequency down-converted and passed through a low pass filter, sampled and passed through the digital matched filter. The output of the matched filter is passed through a decision device to get the demodulated data. We observed that the output of the matched filter, and consequently the performance of the receiver, will remain the same as long as the sampled values do not change. This leads to a fundamental question - *How useful is the analog waveform between the sampling instants for the receiver?*. Can another message signal be brought to baseband, in the period between the sampling instants? Then this combined signal can be sampled using the same ADC, thereby reducing the analog components, (like number of multipliers, low pass filters and ADCs) of the receiver.

The incoming signal needs to be transformed in such a way as to bring multiple signals simultaneously to baseband. Furthermore, it should be possible to demodulate each of

1. Introduction

them without degradation in performance. To achieve this we multiply the incoming signal with a *down-conversion function* rather than with a single frequency. After filtering out high frequency components and digitizing the signal, we get the sampled values of different channels that can be separated. We have derived the exact form of this downconversion function.

2. Proposed Receiver

2.1. Transmitter Model

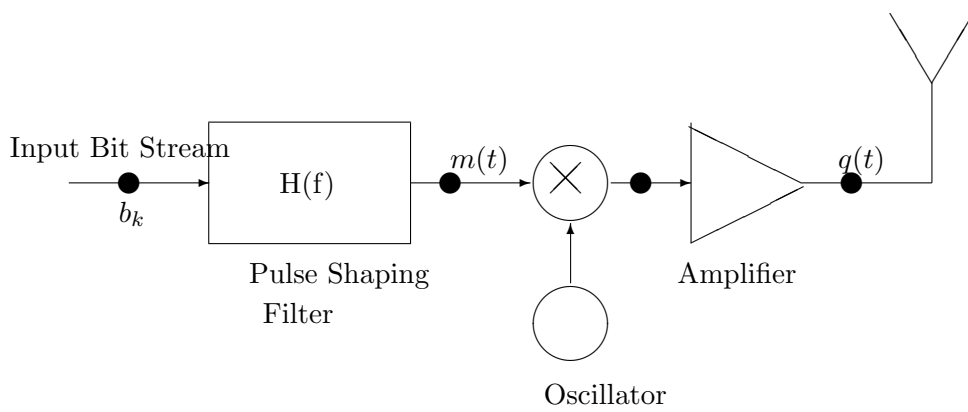

Figure 2.1.: Transmitter for one channel

The transmitter is modeled as a *BPSK* transmitter as shown in Figure 2.1. The input sequence $\{b_k\}$ arrives at a bit rate of R_b ($T_b = \frac{1}{R_b}$). A pulse shaping filter $H(f)$, with an impulse response $h(t)$, is used to limit the bandwidth of the transmitted signal to W . The output of the matched filter $m(t)$ is given by

$$m(t) = b_k h(t - k \cdot T_b) \quad (2.1)$$

It is assumed that the filter is of unit energy, that is

$$\int_{-\infty}^{\infty} |H(f)|^2 = 1 \quad (2.2)$$

This signal is *BPSK* modulated at a carrier frequency of f_c giving,

$$q(t) = \sqrt{\frac{E_b}{T_b}} m(t) \cos 2\pi f_c t \quad (2.3)$$

It is assumed that there are N such transmitters, transmitting at carrier frequencies $\{f_{c,i}\}_{i=0}^{N-1}$. We propose a receiver that will be able to demodulate all the N channels at the same time.

2. Proposed Receiver

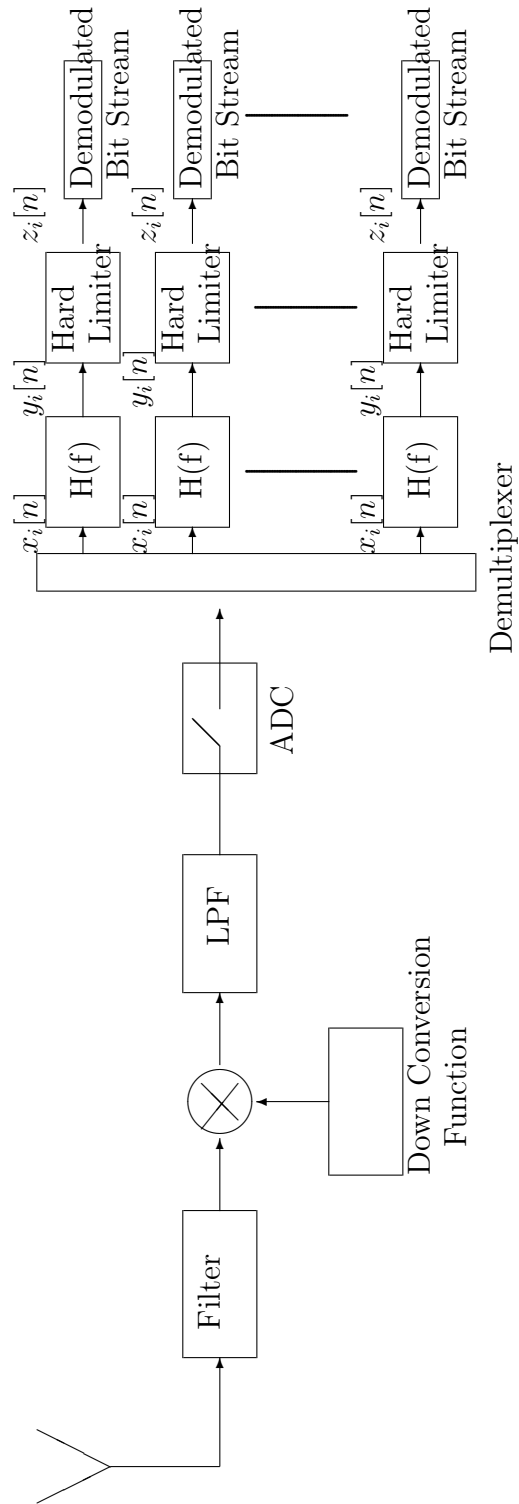

Figure 2.2.: Proposed Receiver

2.2. Proposed Receiver

The proposed receiver is shown in Figure 2.2. We assume here, that the frequency synchronisation and timing recovery has already been done. These operations are done on the digitized signal, it can be seen that they can be performed in the proposed scheme also. The received signal $r(t)$ is given by

$$r(t) = \sum_{i=0}^{N-1} \sqrt{\frac{E_b(i)}{T_b}} m_i(t) \cos 2\pi f_{c,i} t + w(t) \quad (2.4)$$

where $w(t)$ is additive white gaussian noise. This needs to be filtered for proper functioning. We will discuss this later in Section 2.4. At present, it is assumed that the filter allows the message signals to pass undistorted.

$$r_{\text{BPF}}(t) = \sum_{i=0}^{N-1} \sqrt{\frac{E_b(i)}{T_b}} m_i(t) \cos 2\pi f_{c,i} t + n(t) \quad (2.5)$$

where $n(t)$ is the noise that passes through the filter. This signal is multiplied by the down-conversion function $d(t)$. (We will quantify the properties of the downconversion function in section 2.3.1)

$$s(t) = r_{\text{BPF}}(t) \cdot d(t) \quad (2.6)$$

This is passed through a low pass filter of bandwidth W_{LPF} . Suppose that we get the output as s_{LPF} . This is sampled at a rate of $R_S = N \cdot K \cdot R_b$, (where K is the oversampling rate) giving the discrete signal $x[n]$, which is demultiplexed into N signals, $\{x_i[n]\}_{i=0}^{N-1}$ where

$$x_i[n] = x[nN + i] \quad \text{where, } 0 \leq i < N \quad (2.7)$$

Each of these digital streams is passed through the corresponding matched filter. It is *desired* that the matched filter output $z_i[k]$ is same as that of the corresponding channel in the conventional parallel receiver given in Figure 2.3

2. Proposed Receiver

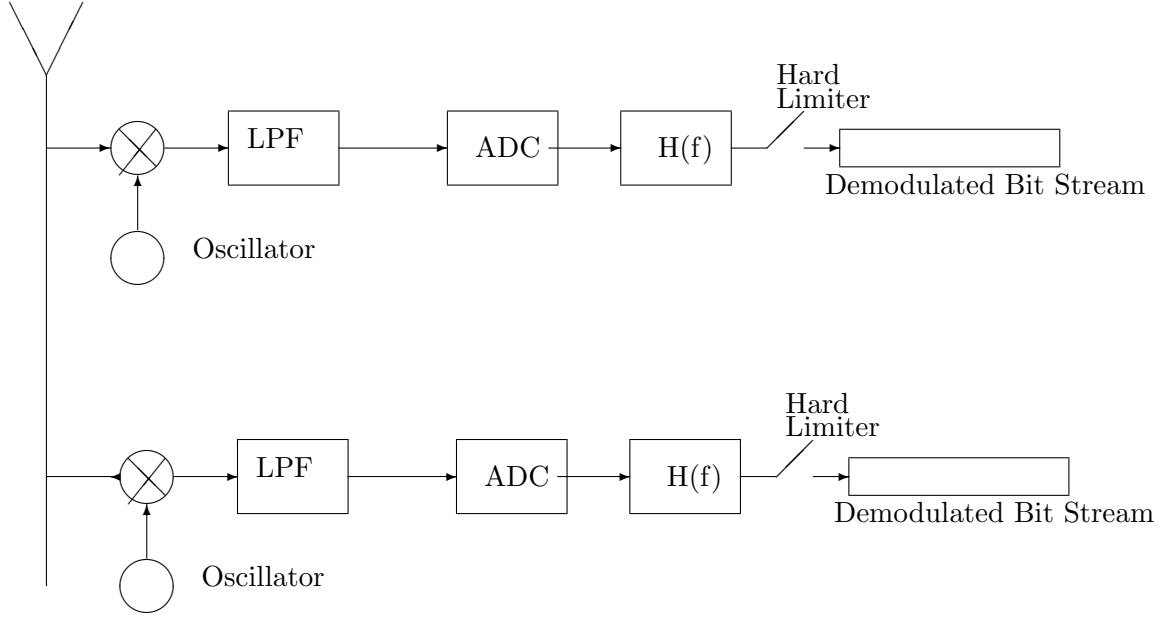

Figure 2.3.: Conventional Parallel Receivers

2.3. Down-Conversion Function

2.3.1. Properties

The down-conversion function should be symmetric for all center frequencies, so it must be of the form

$$d(t) = \sum_{i=0}^{N-1} g_i(t) \cos 2\pi f_{c,i} t \quad (2.8)$$

The function $g_i(t)$ should also be symmetric with respect to the points at which it is sampled. Thus it should be periodic with a period of $\frac{N}{R_S}$, that is

$$g_i(t) = g_i\left(t - \frac{kN}{R_S}\right) \quad \text{for all } k \quad (2.9)$$

The $g_i(t)$ should be chosen such that we get the *desired* output at the output of the matched filter.

2. Proposed Receiver

2.3.2. Design

In this section we will try to find the most general form of the down-conversion function. In the first analysis we ignore the channel noise. As given by Eq. 2.8

$$d(t) = \sum_{i=0}^{N-1} g_i(t) \cos 2\pi f_{c,i} t$$

$$s(t) = r_{\text{BPF}}(t) \times d(t) \quad (2.10)$$

$$= \sum_{k=0}^{N-1} \sqrt{\frac{E_b(k)}{T_b}} m_k(t) \cos 2\pi f_{c,k} t \times \sum_{k=0}^{N-1} g_k(t) \cos 2\pi f_{c,k} t \quad (2.11)$$

$$= \frac{1}{2} \sum_{k=0}^{N-1} \sqrt{\frac{E_b(k)}{T_b}} m_k(t) g_k(t)$$

$$+ \frac{1}{2} \sum_{k=0}^{N-1} \sum_{\substack{m=0 \\ m \neq k}}^{N-1} \sqrt{\frac{E_b(k)}{T_b}} m_k(t) g_m(t) \cos 2\pi (f_{c,k} - f_{c,m}) t$$

$$+ \frac{1}{2} \sum_{k=0}^{N-1} \sum_{m=0}^{N-1} \sqrt{\frac{E_b(k)}{T_b}} m_k(t) g_m(t) \cos 2\pi (f_{c,k} + f_{c,m}) t \quad (2.12)$$

The lowpass filter should filter out both the double summation terms, so we get

$$s_{\text{LPF}}(t) = \frac{1}{2} \sum_{k=0}^{N-1} \sqrt{\frac{E_b(k)}{T_b}} m_k(t) \cdot g_k(t) \quad (2.13)$$

Sampling at the rate R_S we get

$$x[n] = s_{\text{LPF}}\left(\frac{n}{R_S}\right) \quad (2.14)$$

$$= \frac{1}{2} \sum_{k=0}^{N-1} \sqrt{\frac{E_b(k)}{T_b}} m_k\left(\frac{n}{R_S}\right) g_k\left(\frac{n}{R_S}\right) \quad (2.15)$$

Demultiplexing this into different channels, we get

$$x_i[m] = x[mN + i]$$

$$= \frac{1}{2} \sum_{k=0}^{N-1} \sqrt{\frac{E_b(k)}{T_b}} m_k\left(\frac{mN + i}{R_S}\right) g_k\left(\frac{mN + i}{R_S}\right) \quad (2.16)$$

The *desired* output is

$$x_i[m] = \kappa \cdot m_i\left(\frac{mN + i}{R_S}\right) \quad (2.17)$$

2. Proposed Receiver

where κ is some constant.

Thus, we get

$$g_i \left(\frac{m}{R_S} \right) = \begin{cases} 1 & \text{if } i \equiv m \pmod{N} \\ 0 & \text{otherwise} \end{cases} \quad (2.18)$$

Any function that satisfies Eq. 2.9 and Eq. 2.18 can be used as $g_i(t)$ in Eq. 2.8

For symmetry, we can assume that all the $g_i(t)$ are just time shifted versions of each other, that is

$$g_i(t) = g_0 \left(t - \frac{i}{R_S} \right) \quad (2.19)$$

Thus, *one possible* solution is

$$g_i(t) = \sum_{k=-\infty}^{\infty} \text{sinc} \left(R_S \left(t - \frac{i}{R_S} - \frac{k \cdot N}{R_S} \right) \right) \quad (2.20)$$

Let $G_i(f)$ be the Fourier Transform of $g_i(t)$

$$G_i(f) \stackrel{F}{\iff} g_i(t) \quad (2.21)$$

$$\begin{aligned} G_i(f) &= \frac{1}{2R_S} \text{rect} \left(\frac{f}{R_S} \right) \\ &\times \sum_{k=-\lfloor \frac{N}{2} \rfloor}^{\lfloor \frac{N}{2} \rfloor} \frac{R_S}{N} \delta \left(f - \frac{k \cdot R_S}{N} \right) \exp(-j2\pi f \frac{i}{R_S}) \end{aligned} \quad (2.22)$$

Since this function is zero for $|f| > \frac{R_S}{2}$, the summation limits reduce from $\{-\infty, \infty\}$ to $\{-\lfloor \frac{N}{2} \rfloor, \lfloor \frac{N}{2} \rfloor\}$. Here the rect is taken as the Fourier Transform of sinc. Hence it is equal to $\frac{1}{2}$ at $\pm \frac{R_S}{2}$

$$g_i(t) = \sum_{k=-\lfloor \frac{N}{2} \rfloor}^{\lfloor \frac{N}{2} \rfloor} \frac{1}{N} \text{rect} \left(\frac{k}{N} \right) \exp(j2\pi \frac{k \cdot R_S}{N} t) \exp(-j2\pi \frac{k \cdot i}{N})$$

Thus,

$$g_i(t) = \sum_{k=-\lfloor \frac{N}{2} \rfloor}^{\lfloor \frac{N}{2} \rfloor} \frac{1}{N} \text{rect} \left(\frac{k}{N} \right) \exp(j \frac{2\pi}{N} k (R_S t - i)) \quad (2.23)$$

2. Proposed Receiver

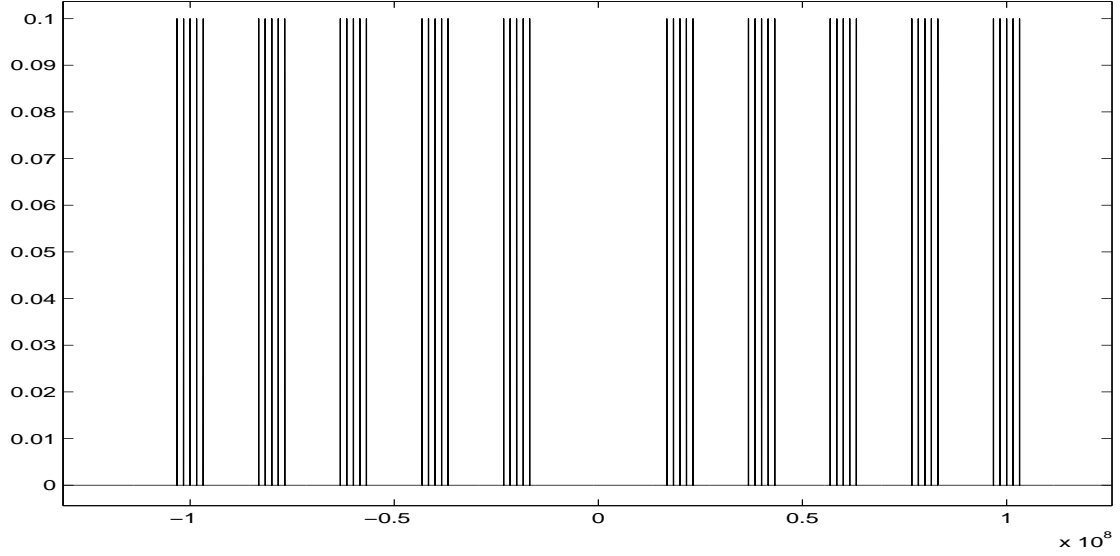

Figure 2.4.: FFT of complete $d(t)$

Hence

$$g_i(t) = \frac{1}{N} \sum_{k=-\lfloor \frac{N}{2} \rfloor}^{k=\lfloor \frac{N}{2} \rfloor} \text{rect}\left(\frac{k}{N}\right) \exp\left(j\frac{2\pi}{N}k(R_S t - i)\right) \quad (2.23)$$

The down-conversion function is shown in Figure 2.5 for the case $N = 5$. Figures 2.3.2 and 2.3.2 show parts of the down-conversion function corresponding to the first and second carrier frequencies respectively. Note the delay between the waveforms ensures that when they will be added, part corresponding to only one carrier frequency will have a peak at the sampling instant and all others will be zero. Figure 2.3.2 shows the sum of $g_0(t) \cos 2\pi f_{c,0}t$ and $g_1(t) \cos 2\pi f_{c,1}t$, illustrating this fact. It is to be noted that 3 other such waveforms $g_i(t) \cos 2\pi f_{c,i}t$ (where $i = 1,2,3,4$) will be added together to form the complete $d(t)$. Figure 2.4 shows the absolute value of the fft of the complete down-conversion function. Each group of 5 impulses represent the frequency domain representation of $g_i(t) \cos 2\pi f_{c,i}t$ for $N = 5$

2. Proposed Receiver

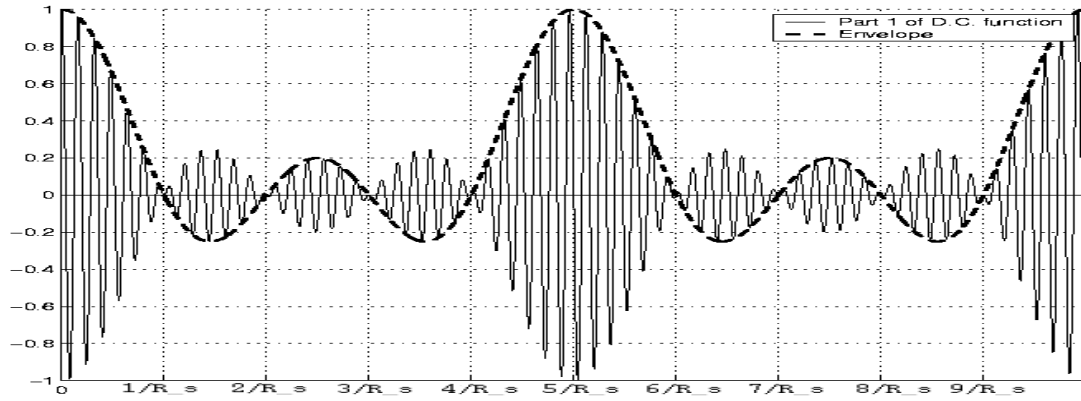

(a) $g_0(t) \cos 2\pi f_{c,0}t$

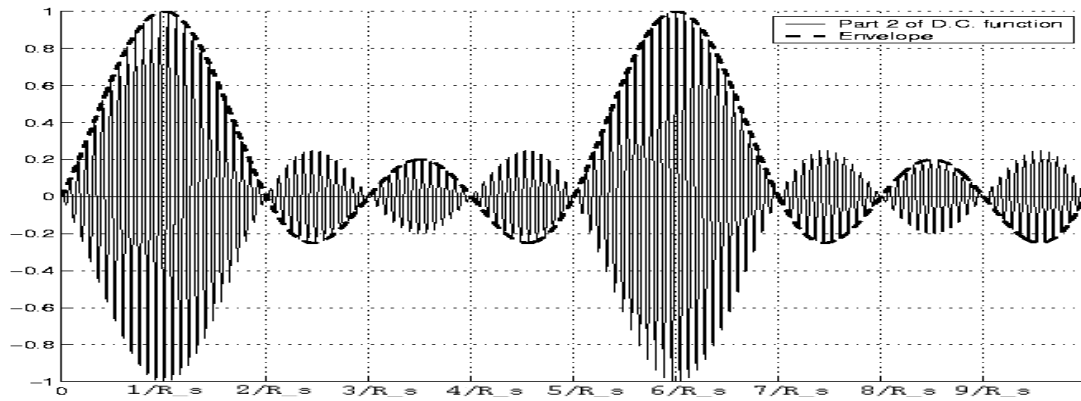

(b) $g_1(t) \cos 2\pi f_{c,1}t$

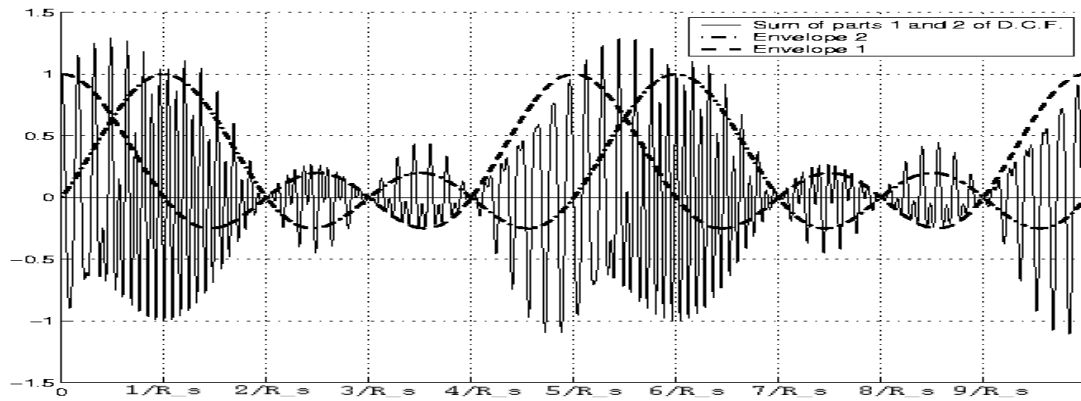

(c) Partial $d(t)$

Figure 2.5.: Down-conversion function waveforms

2. Proposed Receiver

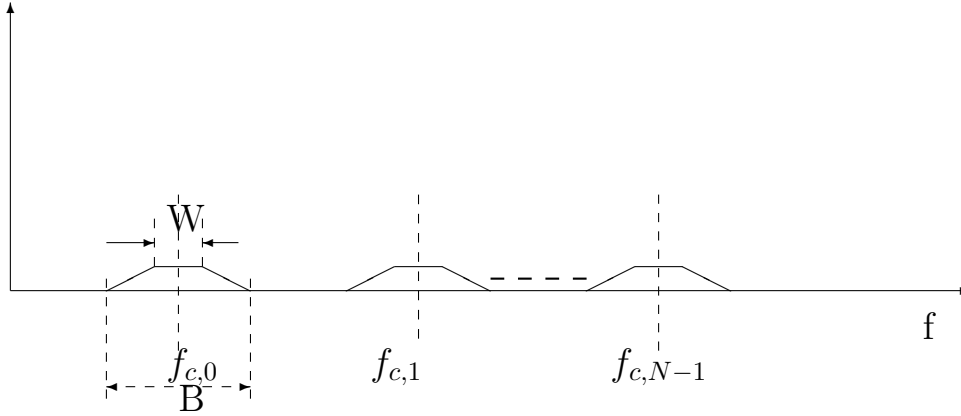

Figure 2.6.: Bandpass filter

2.4. Bandpass Filter

So far we have neglected the presence of noise and other signals. Let us consider what happens when they are present. Anything that is present outside the message bands may cause aliasing when $r_{\text{BPF}}(t)$ is multiplied with the down-conversion function. The role of the bandpass filter array is to avoid any distortion in the message bandwidth. The passbands of this filter array should be centered around the carrier frequencies. The filter's frequency response is shown in Figure 2.6. The passband around each carrier frequency should be greater than W so that the message can pass through undistorted. But we would like to keep the bandwidth as large as possible so that the filter can be realized easily. It can be seen from Figure 2.7 that if the bandwidth B is less than $2\frac{R_s}{N} - W$ then no distortion or aliasing will occur in the message bandwidth W . The filter response between $f_{c,i} + \frac{W}{2}$ and $f_{c,i} + \frac{B}{2}$ need not be flat. So the design of the filter becomes relatively simple.

2. Proposed Receiver

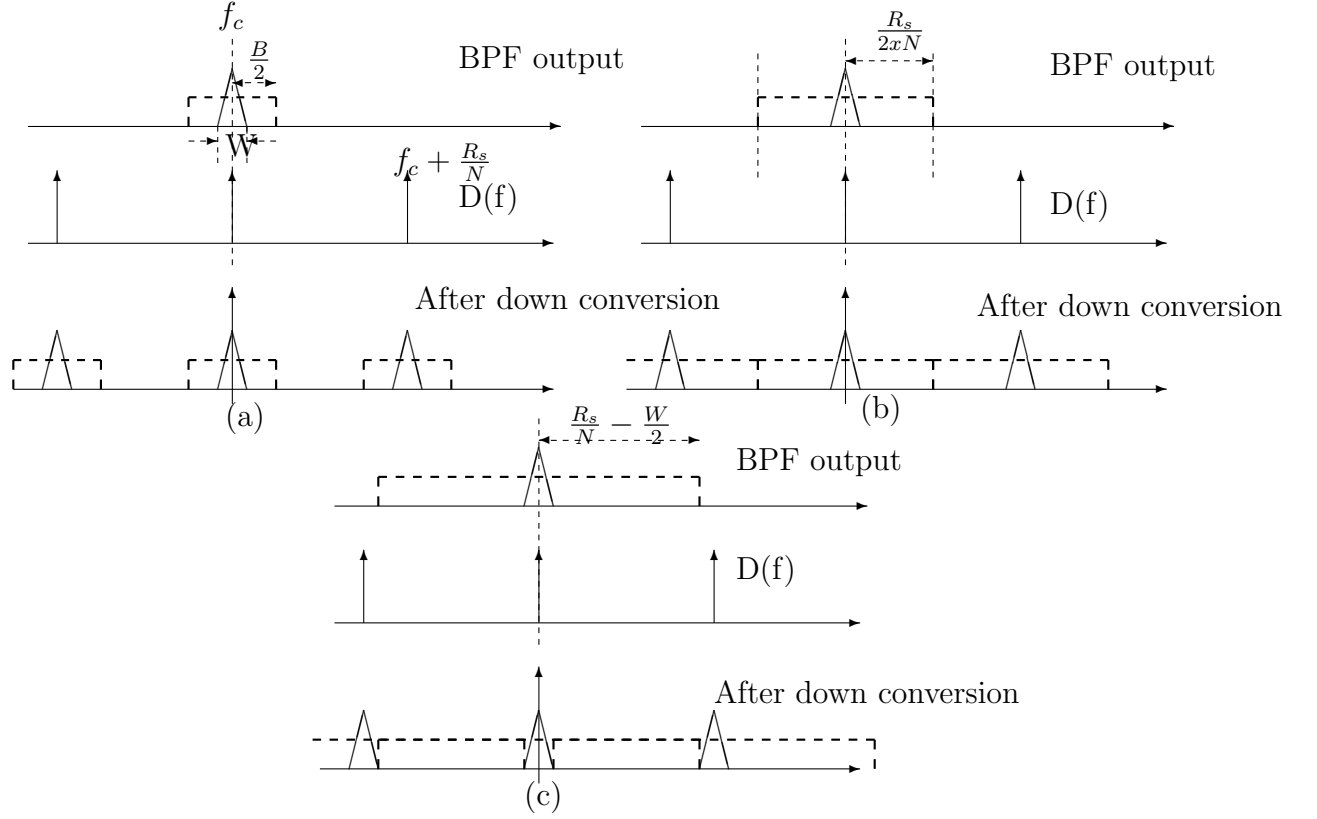

Figure 2.7.: Fourier Transform of the down-converted signal for different bandwidths of BPF, a) for $B < \frac{R_s}{N}$, b) for $B = \frac{R_s}{N}$, c) for $B = 2\frac{R_s}{N} - W$

2.5. Minimum Frequency Separation

Let $S(f)$ be the Fourier Transform of $s(t)$ mentioned in Eq. 2.12.

$$\begin{aligned}
 S(f) &\stackrel{F}{\rightleftharpoons} s(t) & (2.24) \\
 &= \frac{1}{2} \sum_{k=0}^{N-1} \sqrt{\frac{E_b(k)}{T_b}} M_k(f) * G_k(f) \\
 &+ \frac{1}{4} \sum_{k=0}^{N-1} \sum_{\substack{m=0 \\ m \neq k}}^{N-1} \sqrt{\frac{E_b(k)}{T_b}} M_k(f) * G_l(f - \Delta f_{k,m}) \\
 &+ \frac{1}{4} \sum_{k=0}^{N-1} \sum_{\substack{m=0 \\ m \neq k}}^{N-1} \sqrt{\frac{E_b(k)}{T_b}} M_k(f) * G_l(f + \Delta f_{k,m})
 \end{aligned}$$

2. Proposed Receiver

$$\begin{aligned}
& + \frac{1}{4} \sum_{k=0}^{N-1} \sum_{\substack{m=0 \\ m \neq k}}^{N-1} \sqrt{\frac{E_b(k)}{T_b}} M_k(f) * G_l(f - f_{c,k} - f_{c,m}) \\
& + \frac{1}{4} \sum_{k=0}^{N-1} \sum_{\substack{m=0 \\ m \neq k}}^{N-1} \sqrt{\frac{E_b(k)}{T_b}} M_k(f) * G_l(f + f_{c,k} + f_{c,m})
\end{aligned} \tag{2.25}$$

The signal at $\Delta f_{i,j} = f_{c,i} - f_{c,j}$ should not overlap with the message signals at the baseband $\sum_{k=0}^{N-1} \sqrt{\frac{E_b(k)}{T_b}} m_k(t) g_k(t)$.

Let

$$\Delta f_{k,l} = \text{Min}_{i,j} \{ \Delta f_{i,j} \} \tag{2.26}$$

Let $m_k(t)$ and $m_l(t)$ be the messages centered at $f_{c,k}$ and $f_{c,l}$. Thus $\Delta f_{k,l}$ should be large enough so that $m_k(t) g_l(t) \cos 2\pi f_{k,l} t$ should not overlap with $\sum_{k=0}^{N-1} m_k(t) g_k(t)$.

The last (extreme right) alias (message only) of $M_l(f) * G_l(f) + M_k(f) * G_k(f)$ will be at

$$F_1 = \left\lfloor \frac{N}{2} \right\rfloor \frac{R_S}{N} + \frac{W}{2} \tag{2.27}$$

The extreme left alias (with the noise and other signals) of $M_l(f) * G_k(f \pm \Delta f_{k,l}) + M_k(f) * G_l(f \pm \Delta f_{k,l})$ will be at

$$F_2 = \Delta f_{k,l} - \left\lfloor \frac{N}{2} \right\rfloor \frac{R_S}{N} - \frac{B}{2} \tag{2.28}$$

In Figure 2.8 to avoid aliasing $F_x \geq 0$. Thus,

$$\Delta f_{i,j} = |f_i - f_j| \geq 2 \left\lfloor \frac{N}{2} \right\rfloor \frac{R_S}{N} + \frac{B}{2} + \frac{W}{2} \quad \text{for all } i, j \tag{2.29}$$

Note that, the carrier frequencies need not be equi-spaced, rather the separation between any two of them should be greater than a minimum value mentioned in Eq 2.29. Further, the bandwidth or the modulation scheme need not be same for all the channels. Each demultiplexed channel can be separately demodulated corresponding to its modulation scheme and bit rate. For different data rates, however the sampling frequency will be governed by the largest data rate $R_b(i)$.

If two closely placed message signals are to be demodulated, we can consider the combined band as one and they can be separated during the digital processing, just as is done in wideband receivers [5].

2. Proposed Receiver

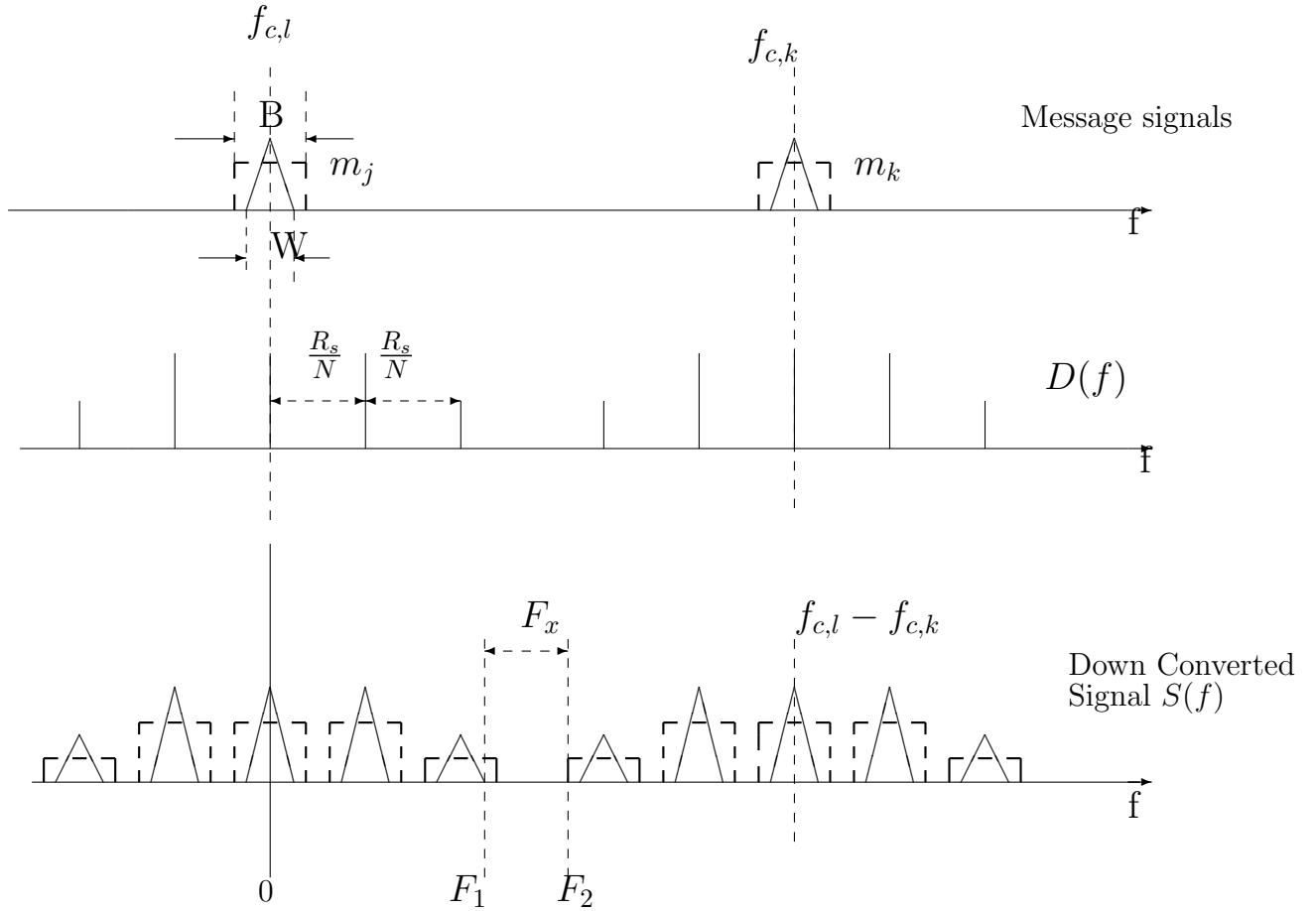

Figure 2.8.: $S(f)$ in frequency domain

2.6. Low Pass Filter Bandwidth

The bandwidth of the lowpass filter W_{LPF} must at least $\lfloor \frac{N}{2} \rfloor \frac{R_s}{N} + W$ to let the *desired* signal, $\sum_{k=0}^{N-1} m_k(t)g_k(t)$, to pass unaffected and cut off all high frequency terms.

This signal is sampled at R_s , so no aliasing will take place as long as $W_{\text{LPF}} \leq \frac{R_s}{2}$. This is the case when N is odd. But when N is even then aliasing will take place. But the down-conversion function is designed in such a way that this the aliasing does not cause distortion of the signal. This can be seen clearly in Figure 2.9 and Figure 2.10. In the two figures the FT on the top represents the signal at the LPF output for $N = 3$ and $N = 4$ cases respectively. We see that on sampling with the sampling frequency R_s the resultant DTFT (bottom waveform in Fig. 2.10) is similar in the two cases and will demultiplexed.

2. Proposed Receiver

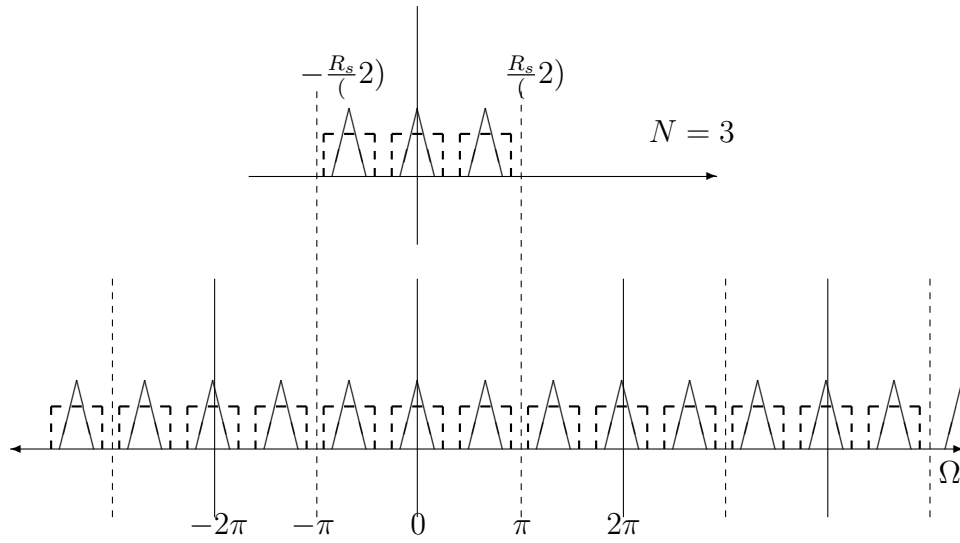

Figure 2.9.: Fourier Transform of LPF output and DTFT of sampled data for $N = 3$ case.

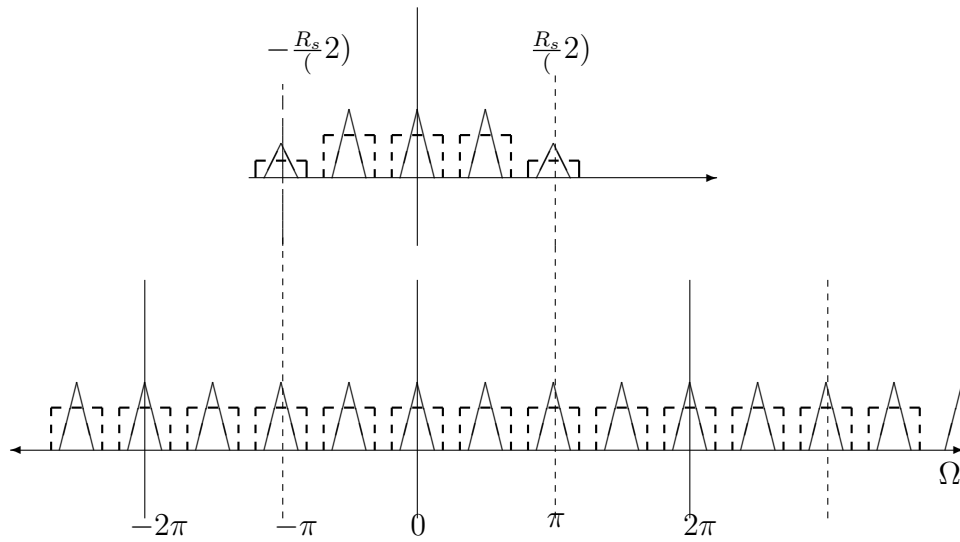

Figure 2.10.: Aliasing effect in $N = 4$ (*even*) case.

3. Performance Analysis

3.1. Auto-Correlation function of $s(t)$

The auto-correlation function of $s(t)$ is given by

$$R_s(t, u) = E[s(t)s(u)] \quad (3.1)$$

$$\begin{aligned} &= E \left[\sum_{k=0}^{N-1} g_k(t) \cos 2\pi f_{c,k}t \sum_{k=0}^{N-1} g_k(u) \cos 2\pi f_{c,k}u \right] \\ &\quad \times E \left[\sum_{k=0}^{N-1} m_k(t) \cos 2\pi f_{c,k}t \sum_{k=0}^{N-1} m_k(u) \cos 2\pi f_{c,k}u \right] \\ &+ E \left[\sum_{k=0}^{N-1} g_k(t) \cos 2\pi f_{c,k}t \sum_{k=0}^{N-1} g_k(u) \cos 2\pi f_{c,k}u \right] \\ &\quad \times E \left[\sum_{k=0}^{N-1} n_k(t) \cos 2\pi f_{c,k}t \sum_{k=0}^{N-1} n_k(u) \cos 2\pi f_{c,k}u \right] \end{aligned} \quad (3.2)$$

Now, this is not a function of $t - u$ so it is not *Wide Sense Stationary*, hence we can not

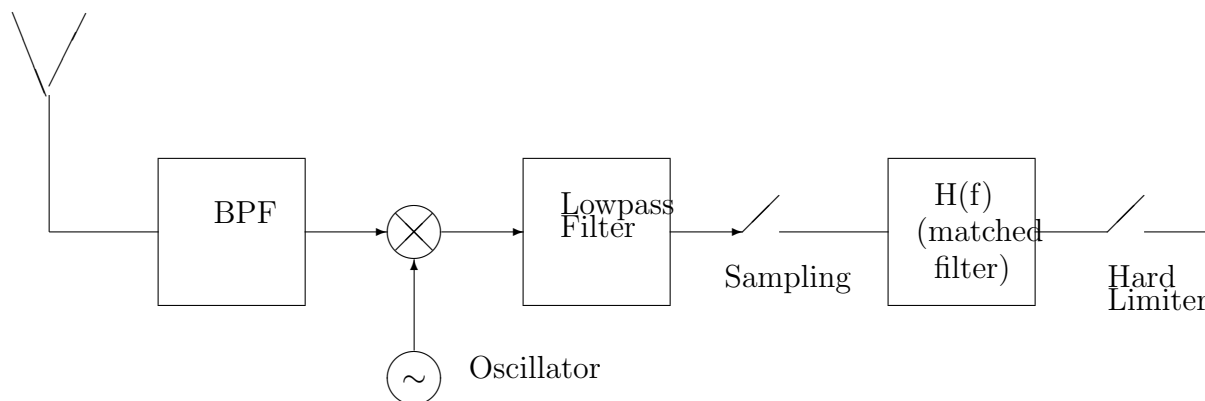

Figure 3.1.: Equivalent Receiver

talk of its power spectral density. This makes the direct analysis of the system difficult. So we consider the receiver, shown in Figure 3.1, which is equivalent to any one channel

3. Performance Analysis

of the proposed receiver. We will see the performance of this system and also why this is equivalent to the proposed receiver in the following section.

3.2. Performance of the Equivalent Receiver

The receiver signal $r(t)$ is given by

$$r_i(t) = \sqrt{\frac{E_b(i)}{T_b}} \cdot m_i(t) \cdot \cos 2\pi f_{c,i}t + w(t) \quad (3.3)$$

where $E_b(i)$ is the signal energy and $w(t)$ is white gaussian noise

$$\begin{aligned} r_{BPF,i}(t) &= \sqrt{\frac{E_b(i)}{T_b}} \cdot m_i(t) \cdot \cos 2\pi f_{c,i}t \\ &+ n_i(t) \cdot \cos 2\pi f_{c,i}t \end{aligned} \quad (3.4)$$

where $n_i(t) \cdot \cos 2\pi f_{c,i}t$ is obtained by passing $w(t)$ through the BPF

$$\begin{aligned} s(t) &= r_{BPF,i} \cdot \cos 2\pi f_{c,i}t \\ &= \frac{1}{2} \left\{ \sqrt{\frac{E_b(i)}{T_b}} \cdot m_i(t) + n_i(t) \right\} \\ &\quad \times \{1 + \cos 4\pi f_{c,i}t\} \end{aligned} \quad (3.5)$$

$$s_{LPF}(t) = \frac{1}{2} \left\{ \sqrt{\frac{E_b(i)}{T_b}} \cdot m_i(t) + n_i(t) \right\} \quad (3.6)$$

This is same as the expression for one channel given by Eq. 2.13 So, the performance of this system should be same as the performance of our proposed system. Now this signal is sampled at a rate of $\frac{R_S}{N}$ giving

$$\begin{aligned} x_i[n] &= s_{LPF} \left(n \frac{N}{R_S} \right) \\ &= \frac{1}{2} \left\{ \sqrt{\frac{E_b(i)}{T_b}} \cdot m_i \left(n \frac{N}{R_S} \right) + n_i \left(n \frac{N}{R_S} \right) \right\} \end{aligned} \quad (3.7)$$

3. Performance Analysis

This is same as the expression for a single channel given by Eq. 2.16. Also both these digital signals are sampled at the same rate. So the output of the matched filter of both of them will be same. Thus if we find the performance of the equivalent system, we will also get the performance of our proposed receiver. The output of the matched filter is

$$\begin{aligned}
 x_{MF}[n] &= x_i[n] * h^*[n] \\
 &= \frac{1}{2} \left\{ \sqrt{\frac{E_b(i)}{T_b}} \cdot m_i \left(n \frac{N}{R_S} \right) \right. \\
 &\quad \left. + n_i \left(n \frac{N}{R_S} \right) \right\} * h^* \left(n \frac{N}{R_S} \right)
 \end{aligned} \tag{3.8}$$

This is sampled at the bit rate R_b at the correct timing instant. The output is y_k

$$E[y_k | b_k = 1] = \frac{1}{2} \sqrt{E_b(i)} \tag{3.9}$$

$$\begin{aligned}
 \text{Var}[y_k] &= \frac{1}{2} \int_{-\infty}^{\infty} \frac{N_0}{2} \text{rect} \left(f \frac{N}{R_S} \right) |H(f)|^2 df \\
 &= \frac{N_0}{4}
 \end{aligned} \tag{3.10}$$

Thus the SNR is given by

$$SNR = \frac{2E_b}{N_0} \tag{3.11}$$

which is same as that of a conventional system. (Refer to Haykins [3]).

3.3. Performance of Proposed Receiver

As argued in the last section, the sampled signal of i^{th} channel of our proposed receiver and that of the equivalent receiver are same. This is then passed through a matched filter which is same in both the cases. Thus, the mean and variance of the sampled output of the matched filter should also be same. This, in turn implies that the performance of both the systems is same.

Hence

$$\boxed{SNR = \frac{2E_b}{N_0}} \tag{3.12}$$

At this SNR the Bit error rate is given by [3],

$$\boxed{P_e = \frac{1}{2} \text{erfc} \left(\sqrt{\frac{E_b}{N_0}} \right)} \tag{3.13}$$

4. Simulation Results

4.1. Carrier Frequency Separation

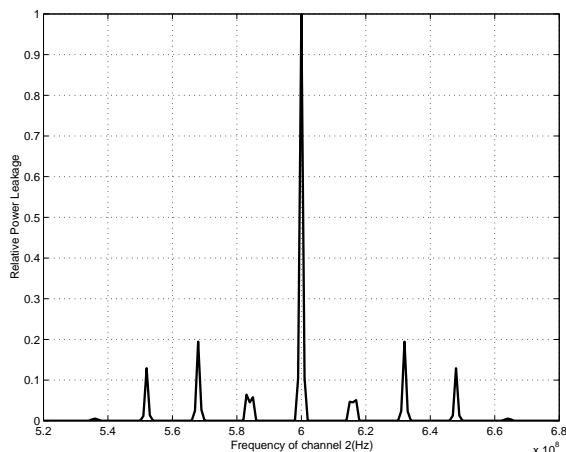

Figure 4.1.: Interference in channel 1 due to signal in channel 0. $f_{c,0} = 600$ MHz and $f_{c,1}$ is swept over 520 MHz to 680 MHz

The minimum difference between two carrier frequencies is given by Eq. 2.29. When we bring the signals closer than this minimum separation, there would be aliasing when the signal is demultiplexed, and the signal received in one channel will leak to other channels. This is verified through simulation. We take $R_b=1$ MHz, $W=2$ MHz, $K = 16$, $B=2$ MHz and $N=5$. Energy of the signal present in all but one channel (centered at $f_{c,0}$) is made zero. The carrier frequency $f_{c,1}$ is swept over 520 to 680MHz, and the power of the demodulated signal in channel 1 is measured. For this case the expected value of $\Delta f_{\min}=66$ MHz. This is verified by the simulation result shown in Figure 4.1. As we go on reducing the frequency separation we see that the interference becomes zero, and then starts again when the difference Δf becomes integer multiple of $\frac{R_b}{N}$ and the sidebands overlap.

4.2. Bandpass Filter Bandwidth

The performance will not be affected by the bandwidth of the bandpass filter, as long as it is in the range specified by Section 2.4. This is also verified by simulation. We took a two channel system and varied the bandwidth of the bandpass filter from W to

4. Simulation Results

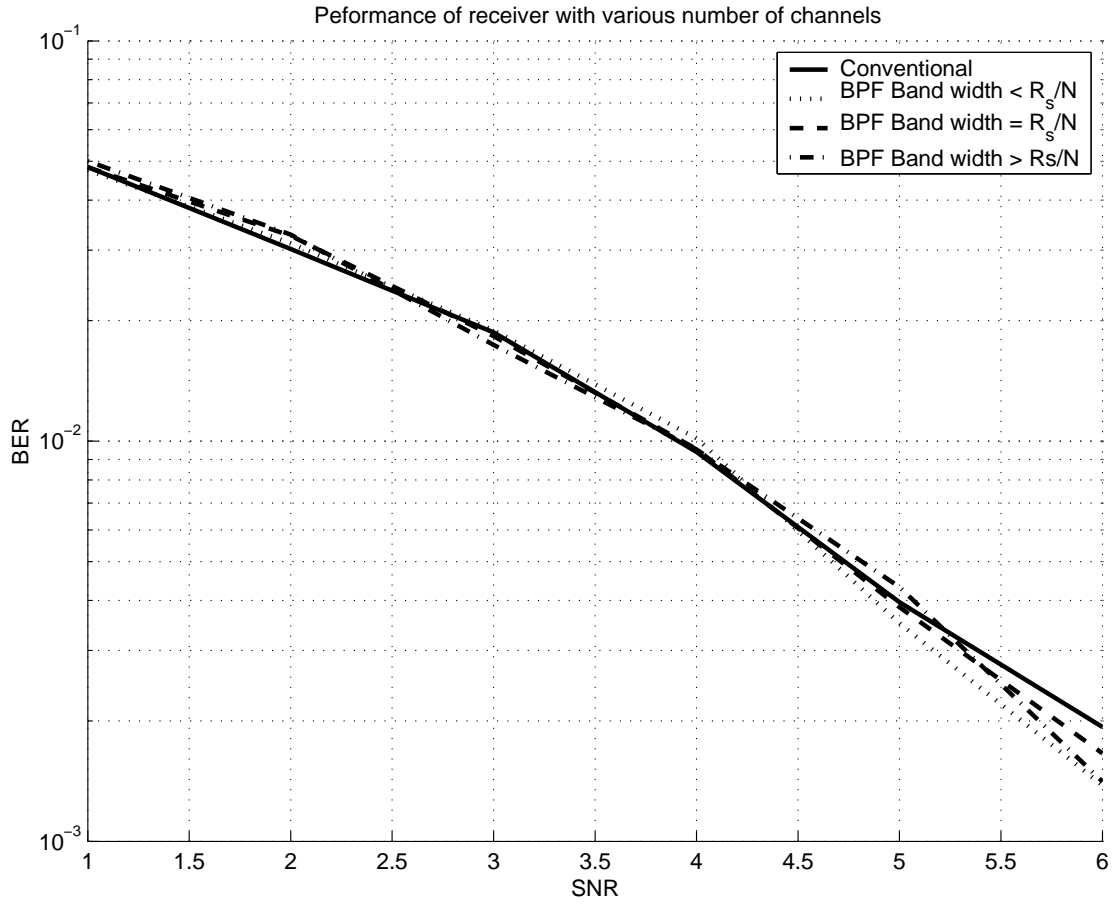

Figure 4.2.: Performance for different bandwidths of the BPF for $N = 2$

$2 \frac{R_s}{N} - W$. The results are shown in Figure 4.2. The performance of the conventional system is also drawn to serve as a reference.

4.3. Number of Channels

We expect the performance to be independent of the number of channels. Figure 4.3 shows the performance curves of our proposed receiver, for two, three and five channels. The performance curve for the conventional receiver is also drawn for reference. It is clear from the figure that the performance is independent of the number of channels.

4. Simulation Results

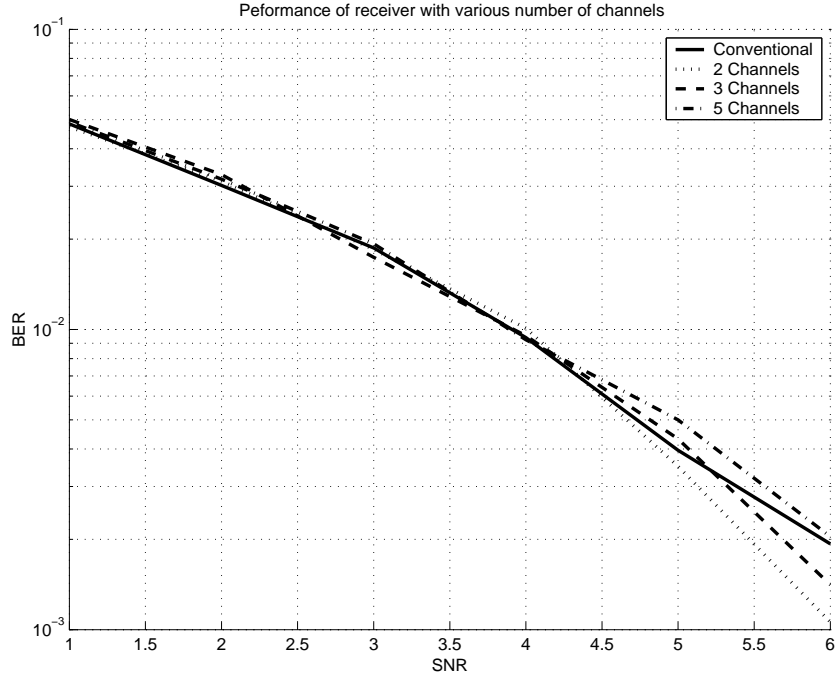

Figure 4.3.: Performance for different values of N

4.4. Analyzing spectrum in GSM

In GSM, the mobile handset has to search the ARFCNs to find out which base station is nearest. There are 124 ARFCNs each of band width 200kHz in a 25MHz band. For simultaneous demodulation of N channels the minimum frequency separation required is given in Table 4.1 (for $K=8$). The most relaxed BPF ($B=\frac{R_s}{N} - W$) has been The Δf_{\min} for our scheme is also shown. As can be seen from the table, in GSM our proposed receiver can simultaneously demodulate 3 channels. By extending the existing scheme to MSK, the overall ARFCN search time can be reduced by a factor of 3.

N	Δf required	Δf_{\min} of proposed receiver
2	12MHz	6.5MHz
3	8MHz	6.5MHz
4	6MHz	10.8MHz

Table 4.1.: Δf required and Δf_{\min} for values of N in GSM.

Note The details of the simulation are mentioned in Appendix A

5. Hardware Realization

Most blocks required for realizing the proposed receiver (refer to Figure 2.2) are common for most receivers. The bandpass filter can be realized easily as there are very mild restrictions on the response of the filter. Other components like lowpass filter and ADC are commonly available. The only unconventional block used is the one used for generating the *down-conversion* function. We propose two solutions for implementing this block. They are shown in Figure 5.1 and Figure 5.2. The basic concept of both the implementations is the same. Now according to Eq. 2.8, $d(t) = \sum g_i(t) \cos 2\pi f_{c,i}t$ where the $g_i(t)$ s are phase shifted versions of each other. In the first scheme, a periodic *sinc* is generated and multiple delay lines are used to get its time shifted copies. The second scheme is based on the fact that a periodic sinc is just the sum of cosines. So the corresponding sines and cosines are generated and are added in correct proportion to get the required phase of the cosines that form the sincs.

The first scheme requires high quality delay lines, while the second scheme requires more hardware in terms of amplifiers and adders to produce the desired phase shift.

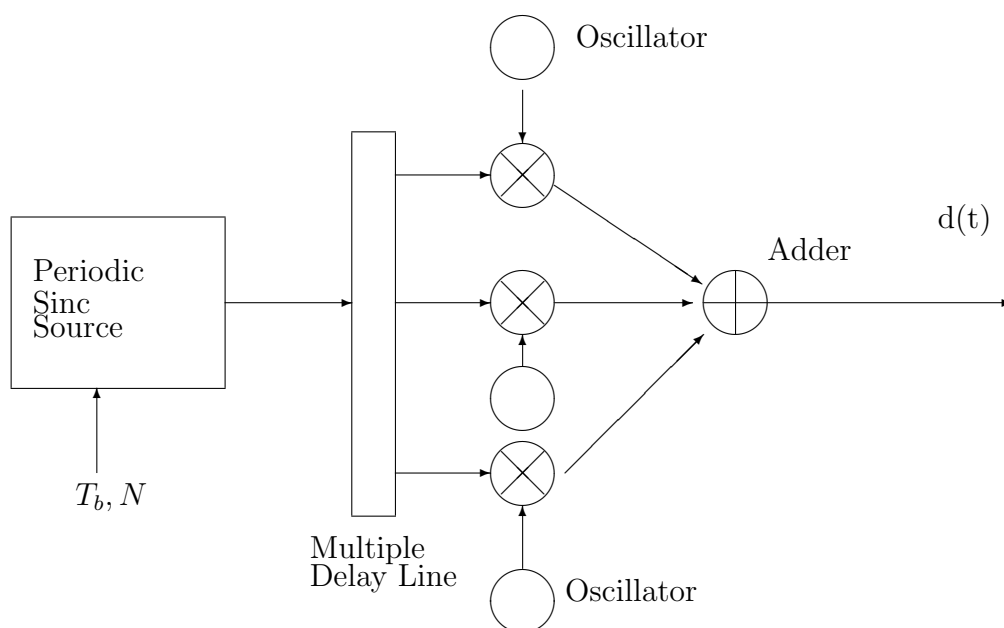

Figure 5.1.: Generating down-conversion function from periodic sines.

5. Hardware Realization

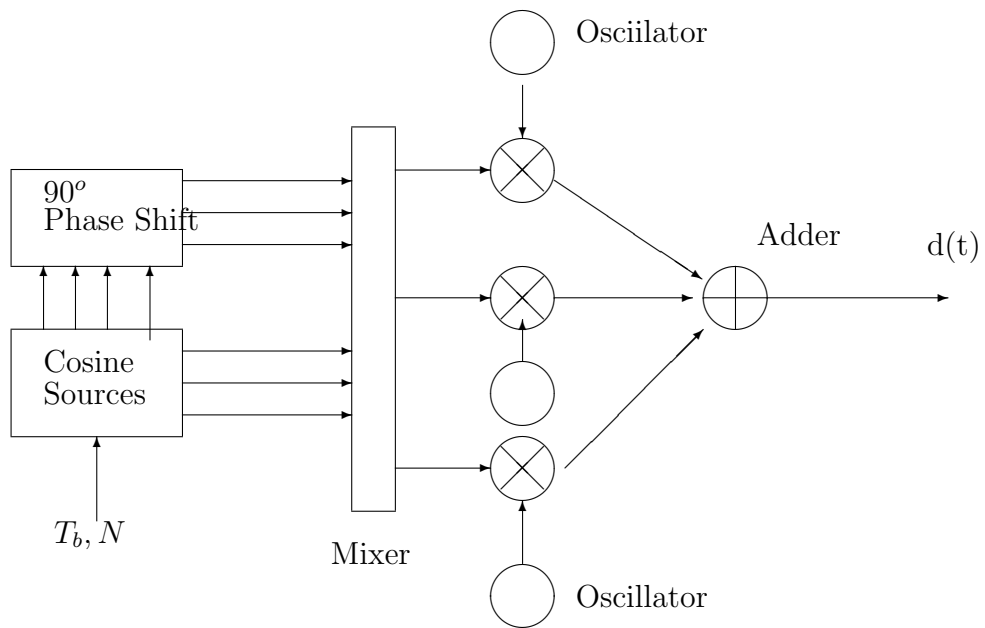

Figure 5.2.: Generating down-conversion function from cosines.

6. Comparison

6.1. Performance Comparison

As shown in Section 3.3 the performance of our proposed receiver is same as that of the conventional receiver. Without error coding this is the best we can get from any receiver.

6.2. Comparison with bandpass sampling

Simultaneous demodulation can also be done by using bandpass sampling method, solutions of sampling frequency etc. have been proposed in [1] and [4]. But there are two big disadvantages of bandpass filtering method compared to the proposed scheme. The first is the quality of band pass filters used. For Band pass sampling very high quality band pass filters with extremely small transition bands and high quality factors are needed. Band width is typically a few hundred kHz to about 1MHz, and the carrier frequency is from a few hundred MHz to a few GHz. These values correspond to a high quality factor of about 500-1000. If the transition band is not small, there will either be aliasing between the the signals that are being brought down to baseband or a higher frequency of sampling will be needed. For the proposed receiver however, it has been shown in section Section 2.4 that the design of the filter is appreciably less complicated. The values for quality factor of typical case like above would be 30-50 in the proposed receiver. The restriction on transition band is also less stringent and it can typically be at least 6-10 times of the pass band itself. The second major disadvantage is making the choice of sampling frequency. Determination of the required sampling frequency of in the receiver becomes very complicated as the number of channels is increased. Also this choice may be extremely sensitive to the change in carrier frequency of any channels, and also to the relative positioning of the channels. No such problems are associated with the proposed receiver. The proposed receiver should hence be definitely superior than Band Pass sampling methods for most applications.

6.3. Comparison with Conventional Parallel receiver

	Conventional Parallel Receiver	Proposed Receiver
Mixers/Multipliers	Requires N mixers, multiplying two RF inputs	Requires N mixers, multiplying an RF input with a one low frequency input. Requires another mixer which multiplies two RF inputs.
Filters	Requires N LPFs, with sharp with cut-offs, and low ripple	Requires 1 LPF, with a larger band-width and similar complexity in terms of ripple and cut off. Also requires N BPFs, with $\frac{f_c}{B} \sim 30 - 50$, sharp cut off not needed and also ripple must be low only in the central part.
ADCs	Requires N ADCs, at sampling rates $R_s = K \times R_b$	Requires 1 ADC, with sampling rate $R_s = N \times K \times R_b$
Additional Hardware	-	Analog periodic <i>sinc</i> generator, phase shifter and an RF N -input adder.

Table 6.1.: Comparison of Hardware Requirements

The hardware comparison of the proposed receiver with the conventional parallel scheme is shown in Table 6.1. This comparison has been done for the *sinc* source and phase shifter implementation of the proposed receiver. The comparison with the second scheme of the conventional parallel receiver will be very similar.

7. Conclusion

In this project we have proposed a novel receiver to simultaneously demodulate multiple frequency multiplexed channels. The performance of this receiver is same as conventional receivers and has advantage in terms of hardware and power requirements. It has limitation on the minimum frequency separation of channels to be demodulated. But it is not a serious limitation as it can be partially removed by combining the wideband receiver concept with the proposed design. Thus this can be considered as an viable alternative to other simultaneous demodulation schemes.

We have designed the receiver for *BPSK* modulation and this can be extended to any other digital demodulation scheme.

A. Simulation Details

A.1. Transmitter

While simulating we have to choose a specific form for the pulse shaping filter $H(f)$. We choose it to *root raised cosine* filter, so that the signal is band limited and there is no *ISI* in the system. The *MATLAB* code for the transmitter is

```
% Generating Random bits
b_b = [0:(n-1)]*T_b ;
b    = randsrc(n,N) ;

[mc tc] = rcosflt(b,R_b,R_b*samplesPerBit,
                  'fir/sqrt', alpha,delay);

m = interp1(tc,mc,t,'linear',0) ;
clear mc tc b_b;

%Frequency Upconversion
tr = m.*cos(2*pi*fc*t)' ;
clear m ;
tr = tr*sqrt(Eb) ;
```

A.2. Channel

We take a simple *AWGN* channel. The noise is spread over the entire simulation frequency, while the messages are band limited. Consequently, the effective SNR is given by

```
SNR_eff = SNR + 10*log10(R_b*(1+alpha)/fsim)
          +10*log10(N);
rcvd = awgn(tr,SNR_eff,'measured') ;
```

A.3. Receiver

The down-conversion function is given by Eq. 2.8, where $g_i(t)$ is given by Eq. 2.23. This is generated as

```
g = [] ;
```

A. Simulation Details

```
k = 2*pi*[0:floor(N/2)]'/N ;
A = ones(1, floor(N/2)+1) ;
A(1) = 0.5*A(1) ;
A(floor(N/2)+1) = (1+mod(N,2))/2 ;
A = 2*A/N ;

for i = 0:N-1
    g(i+1,:) = A*cos(k*(R_S.*t-i)) ;
end

d = sum(g.*cos(2*pi*fc*t)); clear g A;
```

To realize the filters, we have followed the approach given in Prokakis [2], realizing the filters in frequency domain. To filter out any signal, we take its *fft* and multiply it with the filter and then take the *ifft*.

The code for generating the bandpass filter bank is

```
H = [] ;
for i=1:N,
    H = [H BPF(fc(i), 3*R_S/N/2, fsim, df) ];
end

bandMask = ones(N,1) ;
bandpassFilter = H*bandMask ;    clear H ;
```

The code for the receiver is

```
R = fft(rcvd) ; clear rcvd ;
R = fftshift(R) ;
Filtered = R.*bandpassFilter ;
clear R ;
Filtered = ifftshift(Filtered) ;
filtered = real(ifft(Filtered)) ;
clear Filtered ;
%%LPF
S = fft(s); clear s ;
S = fftshift(S) ;
S_LPF = S.*filter; clear S ;

S_LPF = ifftshift(S_LPF) ;
s_LPF = real(ifft(S_LPF)) ;
clear S_LPF ;
```

A. Simulation Details

```
%Sampling
x = downsample(s_LPF,fsim/R_S) ;
clear s_LPF ;

%%Demuxing
y = [] ;
for i=0:N-1,
    y(:,i+1) = downsample(x,N,i) ;
end
clear x ;

%Matched Filtering
mf_out = rcosflt(y,R_b,samplesPerBit*R_b,
                'filter/Fs', mf);
clear y ;

%Sampling
out = downsample(mf_out,samplesPerBit) ;
clear mf_out ;
out = out(2*delay+1:n+delay,:) ;

demodulated = 2*(out>0)-1; %clear out ;
b = b(1:n-delay,:) ;
error = error + sum(abs(demodulated-b)/2) ;

clear demodulated ;
```

A.4. Number of bits to be Simulated

We required to simulate a large number of bits (approx. 50,000) to get reasonably accurate values of the BER. There were $\frac{f_{sim}}{R_b}$ number of simulation points per bit, thereby making the total number of simulation points huge ($\sim 1e9$). This increased the simulation time a lot. To overcome this problem, we simulated the system for $n \sim 100$ bits and repeated the simulation for *bitsrepeat* number of times and counting all the errors.

A.5. Minimum Frequency Separation

$f_{c,0}$ was kept constant at 600 MHz and $f_{c,1}$ was varied from 520 MHz to 680 MHz. The code for this is

```
Interference = [] ;
f2_min = 5.2e8;
f2_max = 6.8e8;
```

A. Simulation Details

```

f2_step = 1e6;
for f2 = f2_min:f2_step:f2_max
    fc = [f1;f2;f3;f4;f5];
    d = sum(g.*cos(2*pi*fc*t));
    %-----TRANSMITTER-----

    b_b = [0:(n-1)]*T_b ;
    b = randsrc(n,1) ;
    [mc tc] = rcosflt(b,R_b,R_b*samplesPerBit,
        'fir/sqrt', alpha,delay);
    m = interp1(tc,mc,t,'linear',0);
    tr = m.*cos(2*pi*f1*t) ;

    %-----RECEIVER-----
    s = tr.*d;
    %%LPF
    S = fft(s); clear s ;
    S = fftshift(S) ;
    S_LPF = S.*filter'; clear S ;
    S_LPF = ifftshift(S_LPF) ;
    s_LPF = real(ifft(S_LPF)) ; clear S_LPF ;

    %Sampling
    x = downsample(s_LPF,fsim/R_S);
clear s_LPF ;

    %%Demuxing
    y = [] ;

    for i=0:N-1,
        y = [y; downsample(x,N,i)] ;
    end

    %Matched Filtering
    mf_out = rcosflt(y',R_b,samplesPerBit*R_b,
        'filter/Fs', mf);
    clear y ;

    Power_Y = var(mf_out);
    Interference = [Interference; Power_Y];
end

```

Bibliography

- [1] Dennins M.A., Stockmaster M., *Direct Bandpass Sampling of Multiple Distinct RF Signals*, IEEE Personal Communications, August 1999.
- [2] Proakis J. G., Salehi M., *Contemporary Communication Systems Using MATLAB*, Brooks/Cole Thomson Learning.
- [3] Haykin S. *Communication Systems*, 4th edition, John Wiley & Sons Inc.
- [4] A. Kohlenberg., *Exact Interpolation of band limited functions* J. Appl Phys. vol 24. no 12 Dec 1953.
- [5] Rhode,Ulrich, et al. *Communication Receivers*, 3rd edition, McGraw-Hill, New York.