

Multiple Access Channels with Feedback

An Achievable Region

Aditya Mahajan
EECS 750

Outline

- MAC Channel without feedback
- Example
- MAC Channel with feedback
- Main Idea of Cover and Leung
- Coding Scheme
- Converse
- Conclusion
- References

MAC Channel without feedback

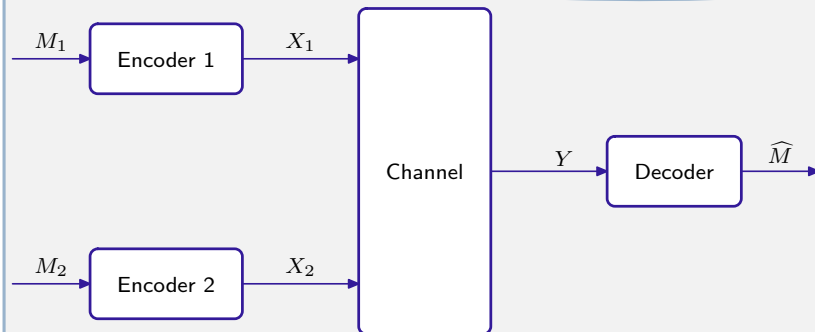

$$\text{Let } \mathcal{R} = \bigcup_{P_{X_1}, P_{X_2}} \left\{ (R_1, R_2) : \begin{array}{l} R_1 < I(X_1; Y | X_2) \\ R_2 < I(X_2; Y | X_1) \\ R_1 + R_2 < I(X_1, X_2; Y) \end{array} \right\}$$

→ The capacity region is \mathcal{R}^* , the convex hull of \mathcal{R} .

(Ahlsvede 1971, Liao 1972)

Example

Noiseless Binary Erasure Channel

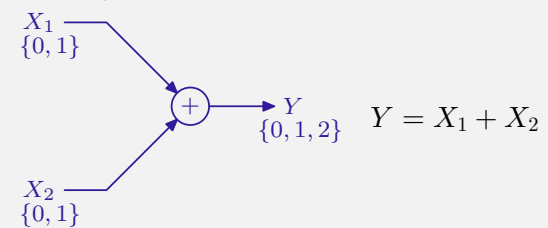

$$\mathcal{R}^* = \left\{ (R_1, R_2) : \begin{array}{l} R_1 < 1 \\ R_2 < 1 \\ R_1 + R_2 < 1.5 \end{array} \right\}$$

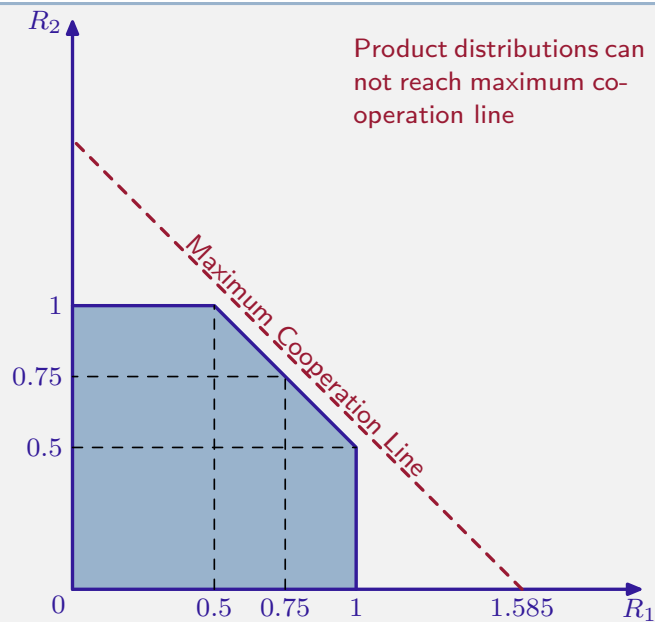

MAC Channel with feedback

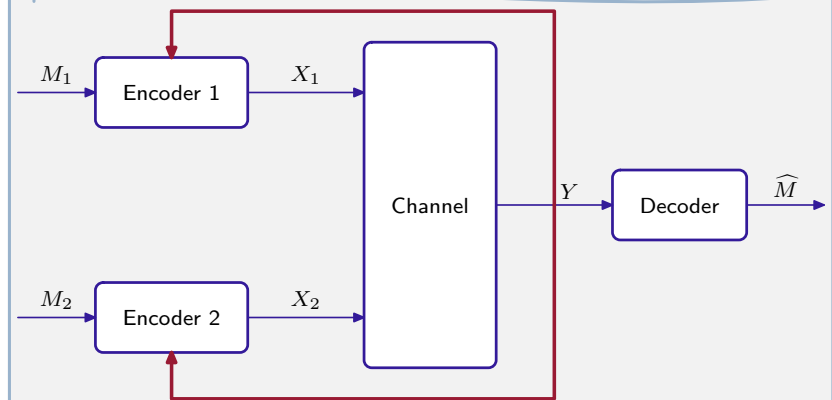

Message

M_1 and M_2 ... independent and equally likely

Encoder

$$X_{1,n} = f_{1,n}(M_1, X_1^{n-1}, Y^{n-1})$$

$$X_{2,n} = f_{2,n}(M_2, X_2^{n-1}, Y^{n-1})$$

Discrete Memoryless Channel

$$P(y_n | x_1^n, x_2^n, y^{n-1}) = P(y_n | x_{1,n}, x_{2,n})$$

Error Event

$$P_e = P(\widehat{M} \neq (M_1, M_2))$$

Main Idea

→ Encoders can communicate using the feedback channel

Can this be used to increase capacity?

→ Product distributions do not reach maximum cooperation limits

→ Joint distribution need to be chosen

→ Encoders can use the feedback channel to communicate with one another

→ Step 1: Encoders communicate their message to each other.

→ Step 2: Communicate to decoder and maximum cooperation limit.

Example – Noiseless BEC

- Both encoders use first m bits to communicate message M_i .
- Decoder: $m/2$ decoded correctly, $m/2$ ambiguous.
- Feedback Channel: M_1, M_2 known at both encoders.
- Use cooperative encoding to for next $n = (\frac{m}{2}) \log 3$ channel uses.

→ Rate: $R_1 = R_2$ and $R_1 + R_2 = \frac{(m+m)}{m + \frac{m}{2} \log 3} = 1.52037$.

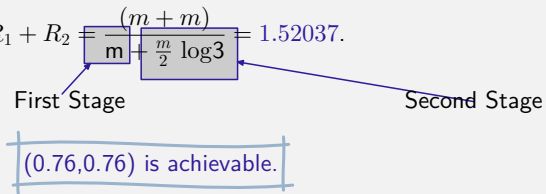

(Gaarder and Wolf 1975)

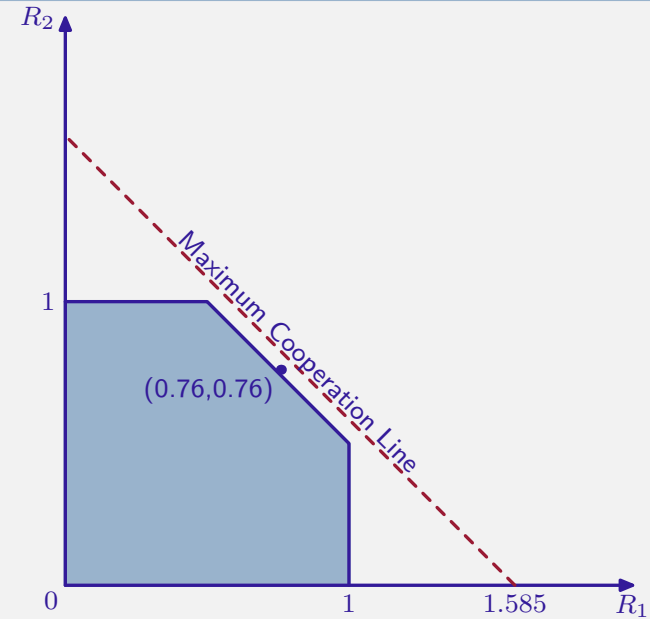

Feedback can increase capacity!

- Can we do better?

Cover and Leung Achievable Region

$$\text{Let } \mathcal{R} = \bigcup_{P_{X_1}, P_{X_2}, U} \left\{ (R_1, R_2) : \begin{array}{l} R_1 < I(X_1; Y | X_2, U) \\ R_2 < I(X_2; Y | X_1, U) \\ R_1 + R_2 < I(X_1, X_2; Y) \end{array} \right\}$$

$$\|\mathcal{U}\| \leq \min\{\|X_1\| \cdot \|X_2\|, \|Y\|\}.$$

\mathcal{R}^* , the convex hull of \mathcal{R} is achievable

(Cover and Leung 1981)

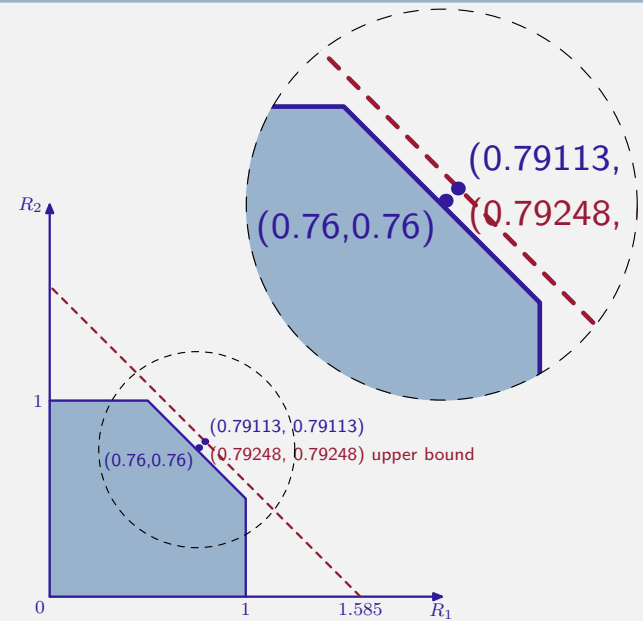

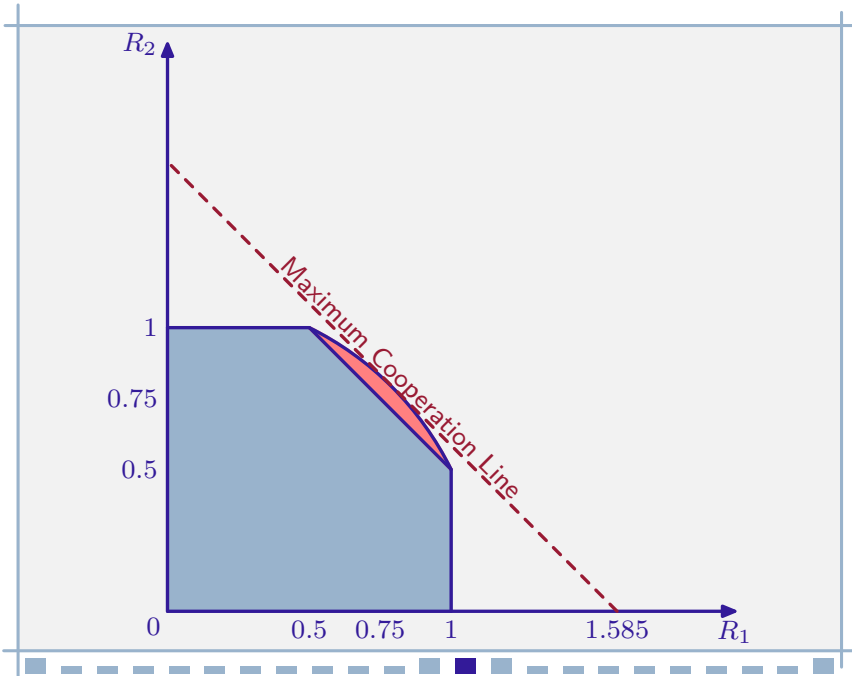

Main Idea of Cover and Leung

Combine

- MAC with correlated sources (Slepian Wolf)
- Block Stationary Coding and Sequential Decoding
- Superposition

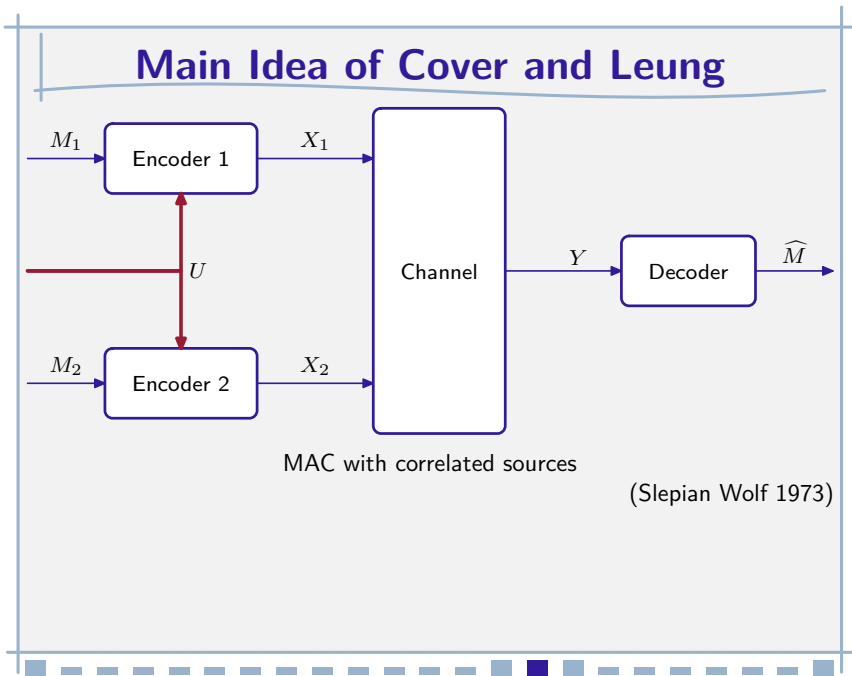

Main Idea of Cover and Leung

- transmit message to other encoder, overshoot for decoder
- introduce U for resolution information and send this in the next block
- Superposition block Markov coding

Coding Scheme

Block Stationary Scheme

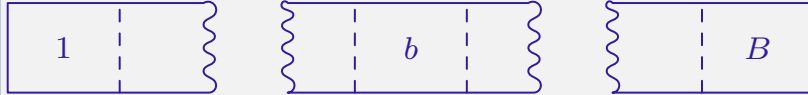

- Generate a resolution codebook P_U
- Use binning to generate conditionally typical codebooks
- Keep track of the receiver's interpretation.

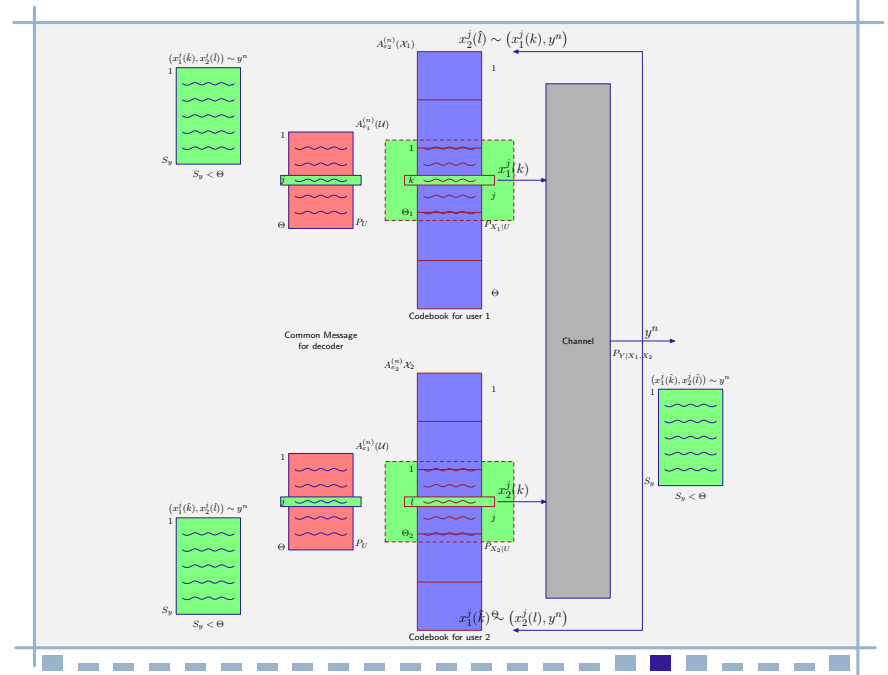

At Encoders

$$x_2^j(\hat{l}) \sim (x_1^j(k), y^n)$$

$$P_{X_1, X_2|Y} = P_{X_1|U} P_{X_2|U} \quad P_U P_{X_1|U} P_{X_2|U} P_{Y|X_1, X_2}$$

$$\frac{1}{n} \log \Theta_1 < I(X_2; Y | X_1, U)$$

$$\frac{1}{n} \log \Theta_2 < I(X_1; Y | X_2, U)$$

At Decoder

There are two superimposed messages

$$u^n \sim y^n \quad \frac{1}{n} \log \Theta < I(U; Y)$$

$$\|S_Y\| \quad \frac{1}{n} \log \|S_Y\| > \frac{1}{n} \log \Theta_1 + \frac{1}{n} \log \Theta_2 - I(X_1, X_2; Y | U)$$

$$\|S_Y\| < \Theta, \therefore \frac{1}{n} \log \Theta_1 + \frac{1}{n} \log \Theta_2 < I(X_1, X_2; Y | U) + I(U; Y) = I(X_1, X_2; Y)$$

Bounding the Probability of Error

Error Events

- $E_1 = \text{Tx 1 decodes } \hat{l} \text{ incorrectly} < \frac{\epsilon}{5B}$
- $E_2 = \text{Tx 2 decodes } \hat{k} \text{ incorrectly} < \frac{\epsilon}{5B}$
- $E_3 = \hat{j} \text{ decoded incorrectly at decoder} < \frac{\epsilon}{5B}$
- $E_4 = (x_1^j(k), x_2^j(l)) \text{ and } y^n \text{ not jointly typical} < \frac{\epsilon}{5B}$
- $E_5 = \|S_Y\| > \exp_2 n(R_1 + R_2 - I(X_1, X_2; Y | U)) < \frac{\epsilon}{5B}$

$$P_{e,b} \leq P(E_1) + \dots + P(E_5)$$

$$\leq \frac{\epsilon}{5B} + \dots + \frac{\epsilon}{5B} = \frac{\epsilon}{B}$$

$$P_e \leq P_{e,1} + \dots + P_{e,b} + \dots + P_{e,B} < \epsilon$$

Converse

In General CL Region is not tight

- Gaussian Channels (Ozarow 1984)
- Poisson Channels (Bross and Lapidoth 2005)

CL Region tight for

- Binary Erasure MAC (Willems 1984)
- $H(X_1 | Y, X_2) = 0$ (Willems 1982)
- Partial Feedback (Willems 1983)

Conclusion

- Feedback increases capacity of MAC channel
- Encoders use feedback channel to communicate
- New Idea of Block Markov Sequential Coding
- Not tight!

References

- T. M. Cover and C. S. Leung, "Achievable Rate Region for the Multiple-Access Channel with Feedback", IT, May 1981.
- N. T. Gaarder and J. K. Wolf, "capacity region of a Multiple Access Discrete Memoryless Channel can increase with feedback", IT, Jan 1975.
- F. M. J. Willems "Theoretic Results for the Discrete Memoryless Multiple Access Channel", Ph.D. thesis, Oct 1982.
- L. H. Ozarow, "Capacity of the White Gaussian Multiple Access Channel with Feedback", IT, July 1984.
- S. I. Bross and A. Lapidoth "An Improved Achievable Region for the Discrete Memoryless Two-User Multiple-Access Channel with Noiseless Feedback", IT, March 2005.