

**THE COMPLETE ANALYTICAL SIMULATION OF HETEROSTRUCTURE BARRIER
VARACTOR FREQUENCY MULTIPLIERS**

L Dillner¹, M L Oldfield², C M Mann², B E J Alderman³

¹Chalmers University of Technology, SE-412 96 Göteborg, Sweden

²Rutherford Appleton Laboratory, Chilton, Didcot, Oxon, OX11 0QX

³University of Nottingham, UK

Abstract

Planar Heterostructure Barrier Varactor¹ (HBV) frequency multipliers are now demonstrating levels of performance that are better than the best planar Schottky varactor multipliers^{2,3}. For high powered, narrow band HBV triplers, the circuit design is dramatically simplified as the need for both second harmonic idler and bias are removed. For a waveguide tripler the inclusion of movable shorts can ensure that the HBV is optimally matched at both the input and output. However, for fixed tuned broad band HBV triplers this is not the case. For specific applications where pump power is limited it becomes necessary to carefully consider both the HBV and waveguide mount together. The HBV has the advantage that unlike the Schottky varactor there are two design parameters that can be adjusted, allowing the device to be tailored for a specific application. By adjusting the number of barriers and its size, a HBV's capacitance can be kept more or less constant whilst its power handling capability can be adjusted over at least an order of magnitude. Thus it becomes necessary to consider a multiplier's application and the HBV used, hand in hand, if the optimum performance is to be attained over the frequency range required.

This paper describes the analytical simulation of a HBV frequency multiplier. An analytical model for the HBV is incorporated with a fast harmonic balance code allowing

pump power and device parameters to be varied at will. All code is integrated with *Mathematica* and so allows flexible graphical output along with parametric variation of both circuit and HBV. A quick HBV design code⁴ is used to determine the initial starting point for the HBV design. This approach has been taken as it allows fast optimisation of circuit and device parameters. The simulation incorporates movable backshorts and easy adjustment of both waveguide and microstrip filter circuit. It therefore becomes possible to perform animations of the complete multiplier's frequency response as a function of input and output backshort position, number of barriers, device area, pump power, etc. Higher harmonics are also taken into account so quintuplers and septuplers can also be studied. On a 300MHz Macintosh a frequency sweep from 240-360GHz in 6GHz increments takes ≈ 30 seconds for the complete multiplier.

Introduction

Planar HBV triplers are now producing higher efficiencies and output powers than conventional planar Schottky varactors. When this is combined with their automatic cancellation of even harmonics and ability to be engineered for specific applications right the way up to terahertz frequencies it appears that the days for the Schottky are numbered. Because the HBV has more variable parameters other than size and doping level, as is the case with a Schottky, the design of a HBV multiplier can be rather more complex. This is particularly true for broadband fixed tuned devices or higher order multipliers such as quintuplers or septuplers. Starting a custom design from scratch can therefore be a time consuming affair when using a full field simulator such as HFSS etc., even after taking into account the recent improvements in computational speed. In order to quickly examine a particular circuit or HBV's suitability for a specific application we have developed an extremely fast analytical simulator for the complete multiplier. The circuit medium is waveguide and is based on a very simple waveguide geometry which has been chosen for its suitability for simulation using a proven analytical model and its

fabrication via micromachining techniques. With the use of micromachining standard waveguide sizes need not be used, thus to be able to quickly analyse custom waveguide mounts is an advantage. By combining analytical models for the complete RF circuit and the HBV itself a very fast modelling tool is produced

This approach, however, does not take all circuit effects into account, it is therefore intended that it should be used in conjunction with full field simulation, providing a sound starting point for the final design.

Simulation Procedure

The simulation is carried out in the following way:-

1. Determine frequency and power specification of the multiplier to be designed.
2. Design the HBV for the power level and impedance level required.
3. Run the HBV optimisation code (either Harmonic Balance or HBVQuick Design, see below) to determine the embedding impedances required over the frequency range desired.
4. Model waveguide multiplier circuit, using visual comparison, adjust for best match at the input and output.
5. Run full model to determine performance of the complete device.
6. Verify circuit design using HFSS, etc.

(HBVQuick design is available at the website;- <http://04/08/99/devicesim.ee.virginia.edu>)

For this paper we examine a real specification required for astronomy, a fixed tuned HBV tripler. The device is to have a nominally flat frequency response, provide 50 μ W of power for an input power level of 10mW and operate fixed tuned from 250-350GHz.

HBVQuick Design shows that a single barrier GaAs HBV will provide sufficient efficiency and output power.

Target circuit impedances across the band of interest are now provided by an optimisation routine in the *Mathematica* frontend which .

The harmonic balance used is a modified version of the splitting method⁵ to suit HBV frequency multipliers. In most harmonic balance algorithms the non-linear device is excited with a voltage. However, we model the HBV by a voltage-charge model, $V(Q)$, which makes it rather complicated to calculate the current from the voltage. Therefore, we have chosen to excite the diode with a current. Our algorithm can briefly be described as follows.

- 1: An initial displacement current, I_0 , at the pump frequency is estimated.
- 2: The current is integrated to a charge, and the voltage over the non-linear subcircuit is calculated using a voltage-charge model.
- 3: The leakage current, I_{L0} , is calculated from the voltage using a non-linear current-voltage model.
- 4: The voltage over the linear subcircuit is assumed to be equal to the voltage over the non-linear elements.
- 5: The current through the linear subcircuit, I_0' , is calculated from the voltage over the linear subcircuit.
- 6: A new displacement current I_1 is estimated between I_0 and $I_0' - I_{L0}$ as

$$I_1 = I_0 + s(I_0' - I_{L0} - I_0)$$

where the variable s is the two-dimensional splitting factor. A two-dimensional splitting factor is used to make it possible to deal with both the amplitude and the phase of the current.

7: Steps 2-6 are repeated until convergence is reached.

8: The input power is calculated and steps 2-7 are repeated with new current estimations until the set value of the input power is reached

The harmonic balance routine has been turned into a *Mathematica* function 'HBVreflect'. This can then be used in the same way that the functions $\text{Cos}[x]$ and $\text{Sin}[x]$ are used. This allows the *Mathematica* kernel to invisibly link the HBV code with the analytical simulation code. *Mathematica* is used as it can generate excellent graphics including animation. The function 'HBVreflect' is shown below.

?HBVreflect

"HBVreflect[F,Pavail,Is,Rsdc,{Zo1, Zo2, ...}] calculates the performance of a HBV multiplier at a frequency F (Hz) with available power P_{avail} (W), \ Initial current I_s (A), DC series resistance of $R_{\text{sd}}c$ (Ohms) with odd \ harmonic embedding impedances of Z_{o1} (Ohms)."

?SetHBVParam

SetHBVParam[T, A, \Epsilon]b, \Epsilon]d, b, s, Nd, N, \Phi]b, a, E0] sets the listed HBV device parameters.

In the code the diode is pumped with 10mW across a range of frequencies and the optimum impedance is returned for the fundamental and output harmonics.

The structure that is modelled in the Eisenhart and Khan analysis is shown below in figure 1. More information can be found in ⁶

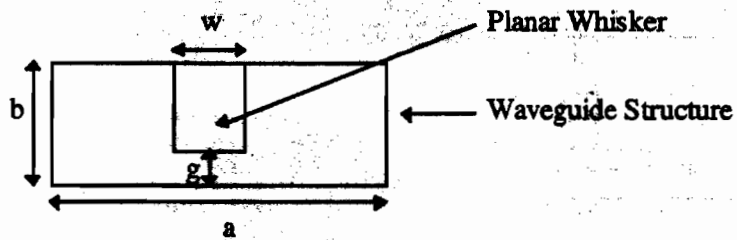

Figure 1: *The basic Eisenhart and Khan waveguide coupling structure.*

The circuit used in the simulation is shown below in figure 2 along with the parameters which can be varied within the code.

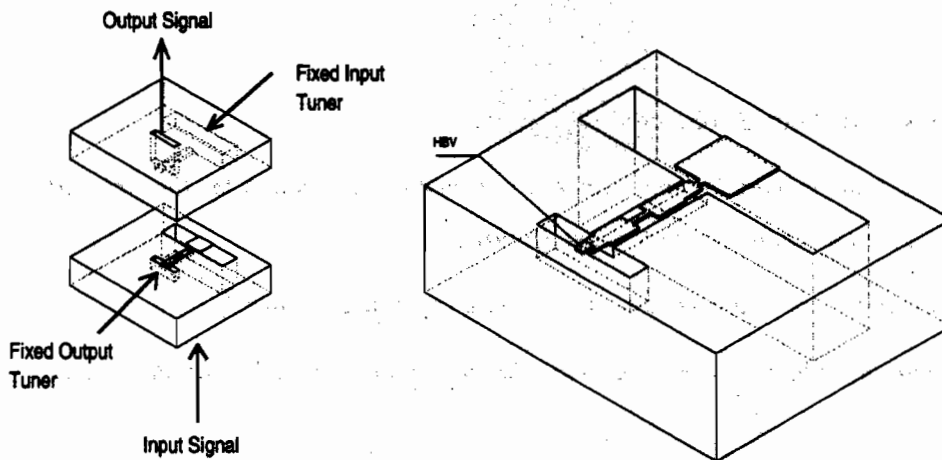

Figure 2: *A schematic of the multiplier geometry modelled.*

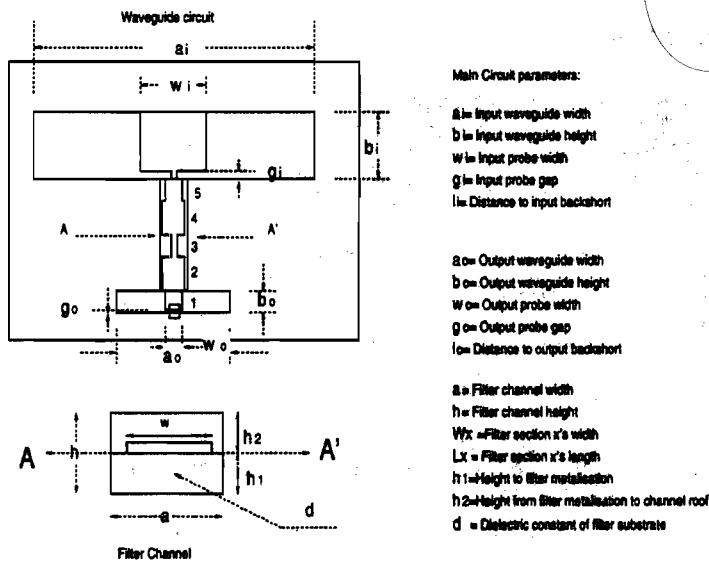

Figure 2(cont'd): The simulated circuit and parameters.

The simulation is carried out as follows:-

1. The ideal input diode embedding impedances are transformed through the filter circuit to provide a goal for the input circuit to meet. (figure 3)
2. The filters dimensions are adjusted and its response confirmed.(figure 4)
3. The input circuit and filter are modified to provide the best matching conditions across the band (figure 5)
3. The output circuit is modified to provide the most optimum impedance match across the band (figure 6)

4. The impedances relating to the best solution is used in the harmonic balance code to determine the complete device's performance (figure 7)

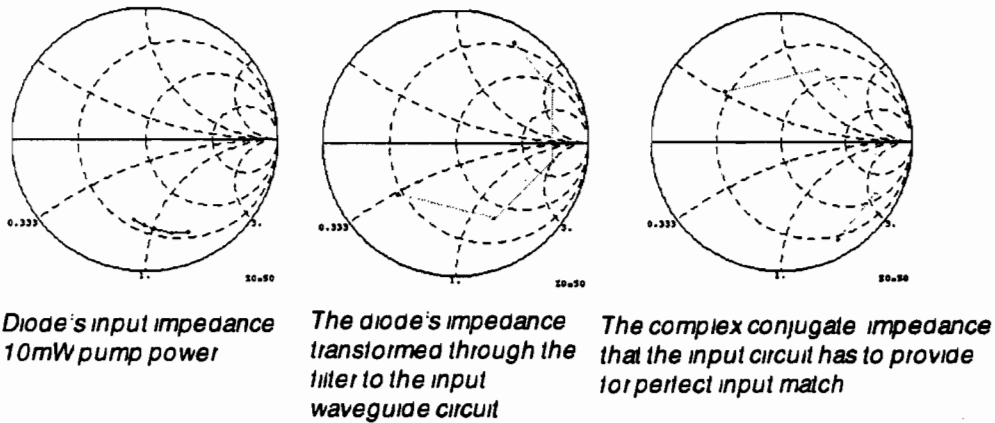

Figure 3: The diodes impedance as a function of input frequency.

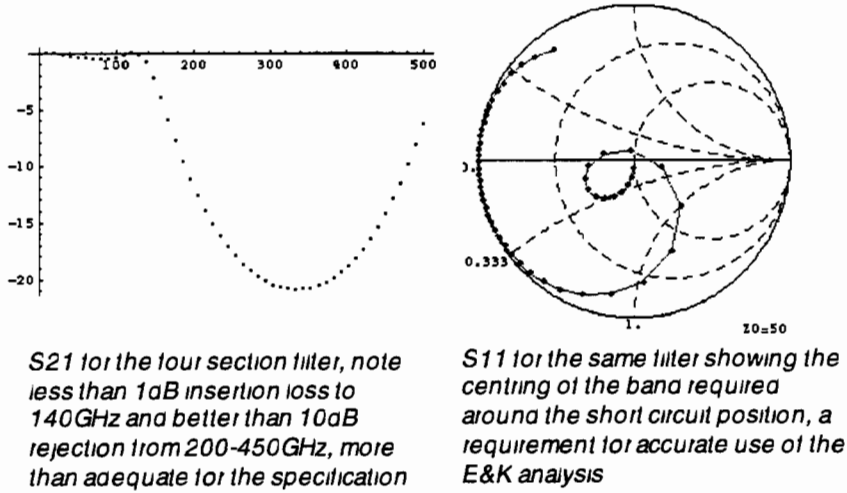

Figure 4: The filter response.

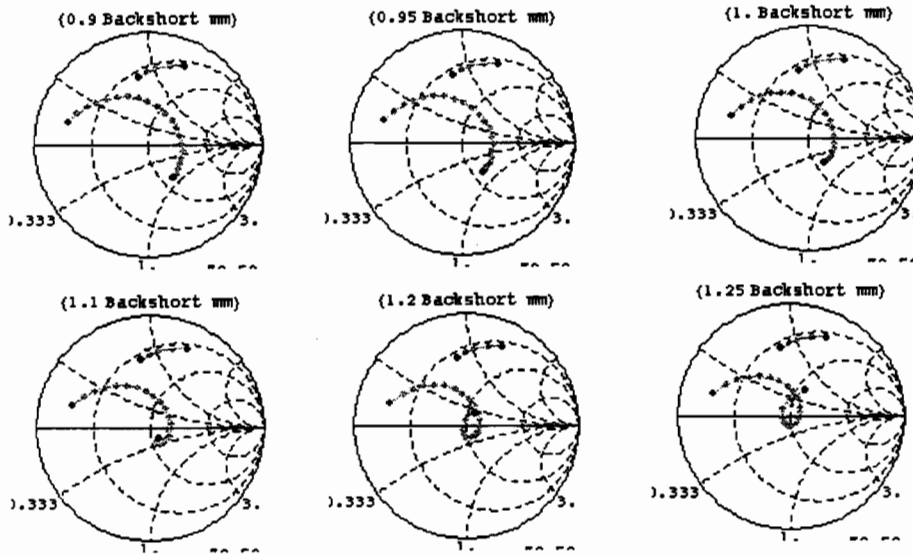
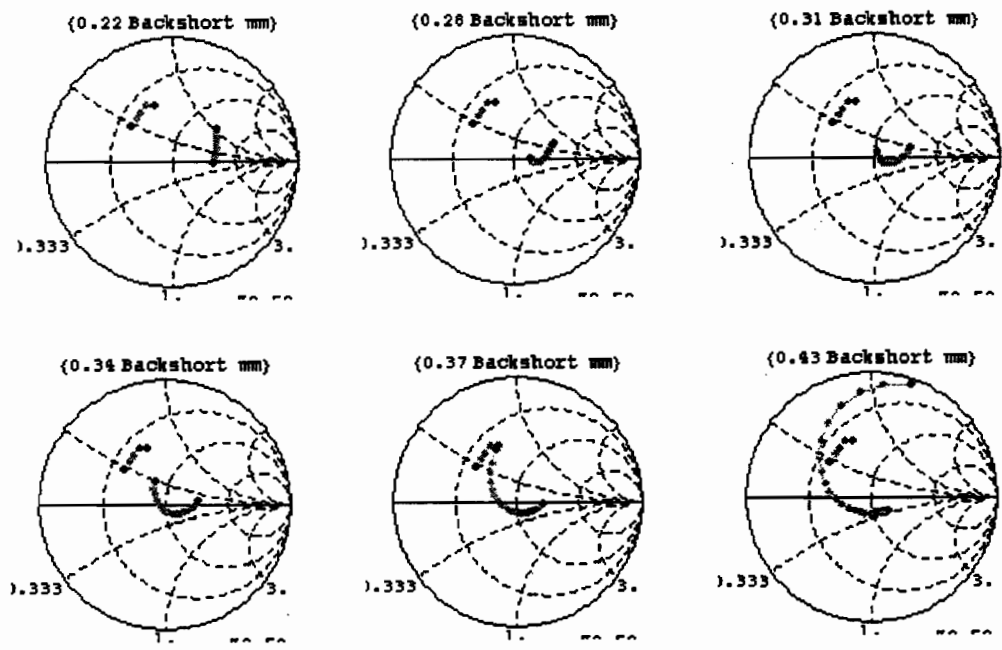

Figure 5: Impedance presented to the diode by the input circuit /filter compared with the ideal impedance required by the diode.



Fig

ure 6 Impedance presented to the diode by the output circuit compared with the ideal impedance required by the diode

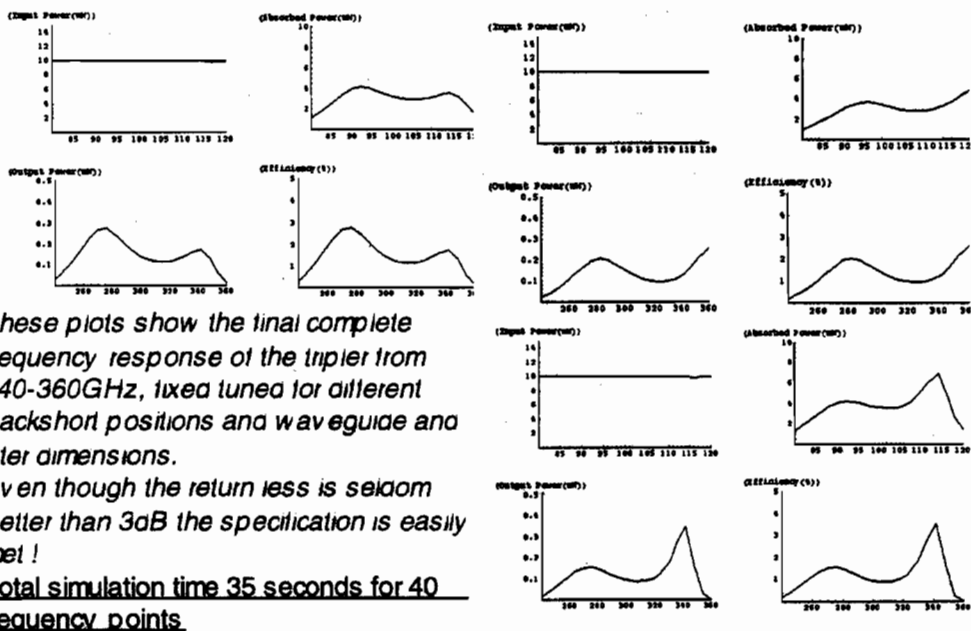

Figure 7: The complete fixed tuned frequency response of the tripler for varying backshort positions.

Discussion

The use of a complete analytical model for a HBV tripler gives valuable insight into its behaviour as a function of frequency. It has shown that very broadband devices (>30% bandwidth) can be realised and also has shown that the input circuit is presently the limiting factor for low powered devices. Analytical models for different waveguide coupling structures are available and could easily be incorporated into the *Mathematica* front-end as importable packages.

Conclusions

A complete analytical model for HBV multipliers has been developed and has been applied to the design of a fixed tuned very broadband HBV tripler. This approach is very fast and adaptable.

Experimental verification as to its accuracy is now underway.

Acknowledgements

The authors wish to thank Professor Stephen Jones for his helpful discussions and for making HBVQuick design generally available.

¹ 'Quantum Barrier Varactor Diodes for High Efficiency Millimetre Wave Multipliers', E. Kollberg, A. Rydberg, *Electron. Lett.*, VOL. 25, no. 25, pp. 1696-1698, Dec. 1989.

² '5-mW and 5% Efficiency 216GHz InP-Based Heterostructure Barrier Varactor Tripler' X.Melique, C. Mann, P. Mounaix, J. Thornton, O. Vanbesien, F. Mollot, and D. Lippens, *IEEE Microwave and Guided Wave Lett.*, Vol. 8, NO. 11, November, 1998

³ 'Effects of Self-Heating on Planar Heterostructure Barrier Varactor Diodes', J.Stake, L.Dilner, S.H.Jones, C.M.Mann, J.Thornton, J.R.Jones, W.L.Bishop, E.Kollberg, *IEEE Transactions on Electron Devices*, VOL. 45, NO.11, November 1998

⁴ 'Design of 100-900 GHz AlGaAs/GaAs Planar Heterostructure Barrier Varactor Frequency Triplers', J.Stake, L.Dillner, S.H.Jones, C.M.Mann, and E.Kollberg, 9th International Conference on Space THz Technology, Pasadena, CA, March 1998

⁵ S. A. Maas, *Nonlinear Microwave Circuits*: Artech House, 1988.

⁶ 'Optimisation of a 250 GHz Schottky Tripler Using Novel Fabrication and Design Techniques', J.Thornton, C.M.Mann, P. de Maagt, *IEEE Transactions on Microwave Theory and Techniques*, VOL. 46 NO. 8, August 1998.