

# Analysis of the Noise Performance of a Hot–Electron Superconducting Bolometer Mixer

B.S. Karasik and A.I. Elantev

*Department of Physics, Moscow State Pedagogical University,  
Moscow 119435, Russia*

## Abstract

A theoretical analysis for the noise temperature of hot–electron superconducting mixer has been presented. The contributions of both Johnson noise and electron temperature fluctuations have been evaluated. A set of criteria ensuring low noise performance of the mixer has been stated and a simple analytic expression for the noise temperature of the mixer device has been suggested. It has been shown that an improvement of the mixer sensitivity does not necessarily follow by a decrease of the bandwidth. An SSB noise temperature limit due to the intrinsic noise mechanisms has been estimated to be as low as 40–90 K for a mixer device made from Nb or NbN thin film. Furthermore, the conversion gain bandwidth can be as wide as is allowed by the intrinsic electron temperature relaxation time if an appropriate choice of the mixer resistance has been made. The intrinsic mixer noise bandwidth is of 3 GHz for Nb device and of 5 GHz for NbN device. An additional improvement of the theory has been made when a distinction between the impedance measured at high intermediate frequency (larger than the mixer bandwidth) and the mixer ohmic resistance has been taken into account.

Recently obtained experimental data on Nb and NbN bolometer mixer devices are viewed in connection with the theoretical predictions.

The noise temperature limit has also been specified for the mixer device where an outdiffusion cooling mechanism rather than the electron–phonon energy relaxation determines the mixer bandwidth. A consideration of the noise performance of a bolometer mixer made from YBaCuO film utilizing a hot–electron effect has been done.

## I. Introduction

During past several years the sensitivity of SIS submillimeter mixers has been increasingly improved. By now a DSB noise temperature of about 4–5 times of the quantum limit has been reached for both waveguide and quasioptical mixers up to about 700 GHz frequencies corresponding to the bandgap in Nb [1-7]. The rapid progress in the development of low noise submillimeter heterodyne receivers faced the researchers to the problem of the further advance towards THz frequencies where the SIS mixers has not been demonstrated yet to perform very well.

Today, perhaps the most promising device which can probably compete to the SIS mixer, is a hot electron superconducting bolometer (HEB) mixer proposed in [8]. Recent experimental studies of the mixer device noise temperature [9,10] as well as of the intrinsic noises [11] have demonstrated a possibility of low noise performance

of the HEB mixer at microwaves and submillimeter waves. A rapid progress in the improvement of the HEB mixer sensitivity is raising an interest in the limiting parameters of such devices.

A theory of HEB mixer was given for the first time by Arams et al. [12]. Despite the only semiconductor InSb mixer device was considered the expression for the mixer gain is useful for superconductor HEB device, as well. More recently this approach was specified for Nb HEB mixer at 20 GHz [9]. The noise temperature of the mixer device was studied using numerical model calculations by Gershenson et al. [8]. As low as a 40 K SSB mixer noise temperature along with a 40 MHz mixer bandwidth has been predicted for Nb device. Since then new superconducting materials such as NbN [13-16] and YBaCuO [17] are used for the development of HEB mixers. Also a new approach has been proposed [18] when an outdiffusion cooling mechanism rather than electron-phonon relaxation should limit the bandwidth of HEB mixer. Here we present a generalized analytic theory for the noise performance of the HEB superconducting mixer applicable for different materials and electron cooling mechanisms.

The paper is designed as follows. In Section II we give a background which is needed for the consequent derivations, i.e. heat balance equation, model of current-voltage (I-U) characteristic and relationship between the voltage responsivity and conversion gain. In Section III the derivations for the mixer intermediate frequency (IF) impedance, voltage responsivity, conversion gain and time constants are given. The expressions for mixer noise temperature due to Johnson noise and thermal fluctuation noise are obtained in Section IV. A brief summary of the noise measurements in HEB mixers known to date is also presented. The peculiarities of the noise performance for novel HEB devices, namely outdiffusion cooled mixer and high- $T_c$  mixer are discussed in Section V.

## II. Heat balance equation and basic relationships

The HEB mixer device is a thin superconducting strip on dielectric substrate cooled below its critical temperature  $T_c$ . Different external factors [e.g. magnetic field, transport current, local oscillator (LO) power] may partially destroy superconductivity and create a resistive state where the film resistance depends on the electron temperature. Depending on the film and substrate materials, and ambient temperature the relaxation of the electron temperature can be different. Thus, in low temperature limit the electron specific heat  $c_e$  is typically much larger than the phonon one  $c_p$ . In this case the electron temperature relaxation is governed by a single time constant  $\tau_\theta$  [19]. For a relatively long film when a temperature spatial distribution is fairly uniform the electron temperature relaxation time is given by  $\tau_\theta = \tau_{e-ph} + \tau_{es} c_e / c_p$ , where  $\tau_{e-ph}$  is the electron-phonon energy relaxation time,  $\tau_{es}$  is the time for phonons to escape to the substrate. When the film is made very thin (thickness  $d \leq 10$  nm)  $\tau_\theta \approx \tau_{e-ph}$ . For very short bridges which length  $L \ll \sqrt{D \tau_{e-ph}}$  the value for  $\tau_\theta$  is given by  $\tau_{diff} \approx (L/4)^2 / D$  [18] ( $D$  is the electron diffusivity). For higher temperatures when  $c_p \geq c_e$  the relaxation of the electron temperature is determined by several time constants like e.g. for YBaCuO film. The consideration of this case is given in Section V.

If one assumes the distribution of the electron temperature along the film to be uniform ("lumped" bolometer) the following heat balance equation is valid:

$$c_e V \frac{\partial \theta}{\partial t} = -\Pi(\theta, T) + \mathcal{W} + \alpha P_{rad}. \quad (1)$$

Here  $\Pi(\theta, T)$  is the flow of heat from electrons to surrounding,  $I$  is the bias current,  $U$  is the voltage across the film,  $P_{rad}$  is the incident radiation power,  $V$  is the mixer volume and  $\alpha$  is the radiation coupling factor. A certain form of  $\Pi(\theta, T)$  function depends on material and device geometry. For instance, for lumped Nb hot-electron bolometer [20]:

$$\Pi(\theta, T) = AV(\theta^4 - T^4), \quad (2)$$

where  $A \approx 10^4 \text{ W cm}^{-3} \text{ K}^{-4}$ .

In order to derive the mixer characteristics as functions of IF the heat balance equation should be supplemented with a certain relationship between voltage  $U$  and current  $I$  which, in general, can not be stated *a priori*. The formal equation is

$$U = U(\theta, I) \quad \text{and} \quad dU = \frac{\partial U}{\partial \theta} \frac{d\theta}{dI} dI + \frac{\partial U}{\partial I} dI \quad (3)$$

For frequencies  $f \gg \tau_{\theta}^{-1}$  the electron temperature does not respond to the current change therefore the relationship between  $U$  and  $I$  is set through  $\partial U / \partial I$ . The very common assumption is  $\partial U / \partial I = R$  ( $R$  is the device dc resistance). However, as it has been shown in [21], this is not necessarily true for HEB superconducting devices. Due to the particular resistivity mechanism (e.g. vortex flow) the I-U characteristic can be non-linear even at high frequencies. This fact has also been mentioned in [22] as rather common for various types of infrared bolometers. A  $\partial U / \partial I$  value [denoted in [22]  $Z(\infty)$ ] must be found experimentally in each particular case. In terms of impedance one can say that the impedance of superconducting HEB decreases with frequency from dc differential resistance  $dU/dI$  to  $Z(\infty)$ . The difference  $dU/dI - Z(\infty)$  appears because of the electron heating and, consequently, reflects the device sensitivity. The proper relationship between the impedance and the voltage responsivity is given in Section III.

The next important step is an equation coupling the mixer conversion gain  $\eta$  and the voltage responsivity  $S$  in the detector mode. It has been obtained by several authors [8,12,18] that an alternating voltage generated in the mixer load at intermediate frequency  $\omega = 2\pi f$  is given by

$$U_{IF}(\omega) = 2S(\omega) \sqrt{P_s P_{LO}} e^{j(\omega t + \varphi)}. \quad (4)$$

Here  $P_{LO}$  and  $P_s$  are the LO and signal powers respectively. Then the conversion gain is given

$$\eta(\omega) = \frac{|P_{IF}|}{|P_s|} = \frac{2|S(\omega)|^2 P_{LO}}{R_L}. \quad (5)$$

### III. Characteristics of the mixer

#### *IF impedance.*

The derivation of the formula for the device IF impedance can be done basing on the assumption stated in previous Section, i.e. the impedance contains both frequency dependent and frequency independent components.

From Eq. 3 we can obtain for the dc impedance:

$$Z(0) = \frac{dU}{dI} = \frac{\partial U}{\partial \theta} \frac{d\theta}{dI} + Z(\infty) = I \frac{\partial R}{\partial \theta} \kappa(0) + Z(\infty), \quad (6)$$

where the function  $d\theta/dI$  is denoted  $\kappa$ . It is obvious that  $\kappa \rightarrow 0$  when  $\omega \rightarrow \infty$ . In the above expression we assume the device operates in constant current mode which is important for a definition of the impedance. Then, in complex form:

$$Z(\omega) = I \frac{\partial R}{\partial \theta} \kappa(\omega) + Z(\infty). \quad (7)$$

Small variation of the current  $\Delta I = \Delta I_0 e^{j\omega t}$  produces the corresponding variation of the electron temperature  $\Delta \theta = \Delta \theta_0 e^{j(\omega t + \varphi)}$ . The relationship between these variations is given using Eq. 1:

$$j\omega c_e V \Delta \theta = -G \kappa(\omega) \Delta I + U \Delta I + I Z(\omega) \Delta I. \quad (8)$$

Here  $G(\theta) = dI/d\theta$  is the thermal conductivity between the electrons and the heat sink. From Eq. 8 we obtain the following equation for complex function  $\kappa(\omega)$ :

$$j\omega c_e V \kappa(\omega) = -G \kappa(\omega) + U + I Z(\omega). \quad (9)$$

Since  $\tau_\theta = c_e V/G$  then from Eqs. 7 and 9 we finally obtain:

$$Z(\omega) = \frac{CR + Z(\infty)}{1-C} \frac{1 + j\omega \frac{\tau_\theta Z(\infty)}{Z(\infty) + CR}}{1 + j\omega \frac{\tau_\theta}{1-C}}, \quad (10)$$

where  $C = I_0^2 (\partial R / \partial \theta) / G$  is the dimensionless self-heating parameter. Denoting  $\bar{\tau} = \tau_\theta (1-C)^{-1}$ ,  $\tau_0 = \tau_\theta Z(\infty) [Z(\infty) + CR]^{-1}$ , and  $Z(0) = [CR + Z(\infty)] (1-C)^{-1}$  we can reduce Eq. 10 to

$$Z(\omega) = Z(0) \frac{1 + j\omega \tau_0}{1 + j\omega \bar{\tau}}, \quad (11)$$

which coincides with the expression used in [21].

In particular case  $Z(\infty) = R$  (see [9,12]):

$$Z(0) = R \frac{1+C}{1-C}, \quad (12)$$

$$\tau_0 = \frac{\tau_\theta}{1+C} \quad (12a)$$

### Voltage responsivity.

Using a similar approach one can derive the expression for the voltage responsivity [22]:

$$S(\omega) = \frac{\alpha}{I} \frac{Z(0)/Z(\infty) - 1}{[Z(0)/R_L + 1][R/Z(\infty) + 1]} \frac{1}{1 + j\omega \bar{\tau}}. \quad (13)$$

Here  $R_L$  is the load resistance,  $\tau^*$  is the apparent time constant given by

$$\tau^* = \frac{[Z(\infty) + R_L][Z(0) + R]}{[Z(0) + R_L][Z(\infty) + R]} \tau_\theta. \quad (14)$$

Using parameter  $C$  Eqs. 12 and 13 can be written as follows:

$$S(\omega) = \frac{\alpha}{I} \frac{C}{1+C} \frac{R_L}{Z(\infty) + R_L} \frac{1}{1 + j\omega\tau^*} \quad (15)$$

$$\tau^* = \frac{\tau_\theta}{1+C \frac{R - R_L}{Z(\infty) + R_L}}. \quad (15a)$$

If  $Z(\infty) = R$  then

$$S(\omega) = \frac{\alpha}{I} \frac{C}{1+C} \frac{R_L}{R + R_L} \frac{1}{1 + j\omega\tau^*} \quad (16)$$

$$\tau^* = \frac{\tau_\theta}{1+C \frac{R - R_L}{R + R_L}} \quad (16a)$$

One should point out that the difference between  $\tau^*$  and  $\bar{\tau}$  arises because of the electro-thermal feedback through the load. If  $R_L \rightarrow \infty$  then  $\tau^* = \bar{\tau}$ .

### Mixer conversion gain.

Here we can give a general expression for the mixer conversion gain. Equations (5) and (15) give

$$\eta(\omega) = 2\alpha C^2 \frac{R_L R}{[Z(\infty) + R_L]^2} \frac{\alpha P_{LO}}{P_{DC}} \frac{1}{\left(1+C \frac{R - R_L}{Z(\infty) + R_L}\right)^2} \frac{1}{1+(\omega\tau^*)^2}, \quad (17)$$

where  $P_{DC} = I^2 R$  is the Joule power dissipated in the device.

Returning to the particular case  $Z(\infty) = R$  one can obtain the well known expression previously derived in [9,12]:

$$\eta(\omega) = 2\alpha C^2 \frac{R_L R}{(R + R_L)^2} \frac{\alpha P_{LO}}{P_{DC}} \frac{1}{\left(1+C \frac{R - R_L}{R + R_L}\right)^2} \frac{1}{1+(\omega\tau^*)^2}. \quad (18)$$

The analysis of the above expression (e.g. given in [9]) and also numerical calculation in [8] show that the conversion gain is theoretically limitless. To ensure this the unpumped I-U characteristic of the mixer must have a

branch with negative differential resistance that in turn can be attained if the bath temperature  $T$  is much lower than the critical temperature  $T_c$ . One more necessary condition to reach high conversion gain is  $C \approx 1$ . This corresponds to the point of the bolometer thermal runaway and the differential resistance of the mixer is very large (see Eq. 12 and Fig. 3). Very often an appearance of large conversion gain is supposed to be followed by the drastic decrease of the mixer bandwidth. It is true only for  $R_L \gg R$  when  $\tau^* \approx \bar{\tau} \rightarrow \infty$  if  $C \rightarrow 1$ . If  $R_L$  value is chosen to be equal  $R$  no significant change of the bandwidth is expected comparing to  $\Delta f = (2\pi\tau_\theta)^{-1}$  set by the bolometer material and its electron temperature. Thus if  $R = R_L$  then  $\tau^* = \tau_\theta$  even for  $C=1$  and for  $\alpha \approx 1$  we obtain

$$\eta(0) = \frac{P_{LO}}{2P_{DC}}. \quad (19)$$

Local oscillator and Joule powers are coupled through the heat balance equation. One can show that if  $T \ll T_c$  and the superconducting transition width is small  $\Delta T \ll T_c$  the conversion gain in Eq. 19 is larger than 1. More details are given in the next Section.

#### IV. Noise in HEB mixer

The conventional mechanisms for bolometer detector noise should be dominating in case of mixer. As much as it concerns an intrinsic noise mechanisms the contributions of Johnson noise and thermal fluctuation noise to the mixer noise temperature have to be evaluated. An important issue is the significant non-equilibrium caused by the LO pumping.

A nonequilibrium theory of the bolometer detector noise has been given by Mather [23]. Mather introduced a dynamic equivalent circuit of the bolometer where the intrinsic reactance in the bolometer response was presented by an equivalent inductance. Similar circuit for more general case  $Z(\infty) \neq R$  is shown in Fig. 1a.

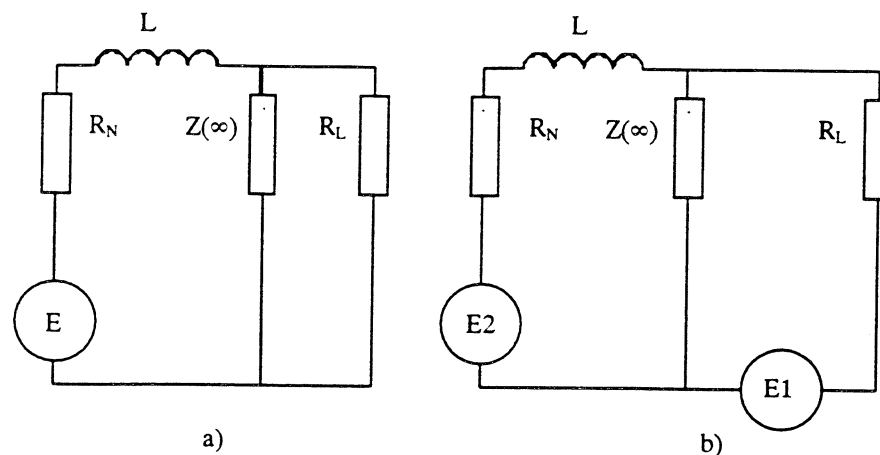

Fig. 1. Equivalent circuits for the HEB.  $E$ ,  $E1$ , and  $E2$  are the equivalent sources of the detected signal or intrinsic noises.

If the circuit parameters are

$$R_N = \frac{Z(0)Z(\infty)}{Z(\infty) - Z(0)}, \quad (20)$$

$$L = \frac{R + Z(0)}{Z(\infty) - Z(0)} \frac{Z(\infty)^2}{R + Z(\infty)} \tau_\theta = -\frac{\tau_\theta}{C} \frac{Z(\infty)^2}{R + Z(\infty)}, \quad (20a)$$

then the output impedance of the circuit is given by Eq. 11. To represent the responsivity correctly the equivalent voltage source must be chosen as

$$E = -\frac{\alpha P_{\text{rad}}}{I_o} \frac{Z(\infty)}{R + Z(\infty)}. \quad (21)$$

To calculate the modification of the noise by the bolometer self-heating one should place the corresponding noise source appropriately in the circuit and find the noise voltage across the load.

### Johnson noise.

Following Mather [23] we assume the classical Johnson noise source  $e_J = \sqrt{4k_B Z(\infty)\theta}$  must appear twice in the bolometer equivalent circuit (see Fig. 2b). Source E1 acts simply as a voltage source in series with the bolometer impedance  $Z(\omega)$ . Mather used  $E2 = -e_J/2$ , however in more general case when  $Z(\infty) \neq R$   $E2 = -e_J Z(\infty)/[Z(\infty) + R]$  is placed to take into account the output noise enhancement caused by the detection of the Johnson noise in the bolometer. Both sources give an actual noise output voltage in the load of

$$e_J^*(\omega) = e_J(\omega) \frac{Z(0) + R}{Z(0) + R_L} \frac{R_L}{R + Z(\infty)} \frac{1 + j\omega\tau_\theta}{1 + j\omega\tau^*}. \quad (22)$$

Hence, the output HEB mixer noise temperature due to Johnson noise is:

$$T_{\text{out}}^J(\omega) = \frac{|e_J^*(\omega)|^2}{k_B R_L} = \frac{4Z(\infty)R_L\theta}{[R_L + Z(\infty)]^2} \frac{1}{\left[1 + C \frac{R - R_L}{Z(\infty) + R_L}\right]^2} \frac{1 + (\omega\tau_\theta)^2}{1 + (\omega\tau^*)^2}. \quad (23)$$

Finally, the SSB mixer noise temperature contribution is given by:

$$T_m^J(\omega) = T_{\text{out}}^J(\omega)/\eta(\omega) = \frac{2\theta P_{\text{DC}}}{\alpha^2 C^2 P_{\text{LO}}} \frac{Z(\infty)}{R} \left[1 + (\omega\tau_\theta)^2\right]. \quad (24)$$

### Thermal fluctuation noise.

This noise is very common for any kind of bolometer having a temperature dependent parameter. The physical cause of the noise are thermal fluctuations of the electron temperature  $\langle \Delta\theta \rangle_\omega = \sqrt{4k_B\theta^2/G} (1 + j\omega\tau_\theta)^{-1}$  producing

the noise voltage across the load. The contribution of this noise source can be given using the circuit in Fig. 2a with E representing the equivalent noise source:

$$e_{TF}(\omega) = -G \langle \Delta\theta \rangle_{\omega} \frac{Z(\infty)}{I[Z(\infty) + R]} = -\frac{\sqrt{4k_B \theta^2 G}}{I} \frac{Z(\infty)}{Z(\infty) + R} \frac{1}{1 + j\omega\tau_{\theta}}. \quad (25)$$

After a number of transformations one can get an output noise voltage across the load:

$$e_{TF}^*(\omega) = \frac{\sqrt{4k_B \theta^2 G}}{I} \frac{C}{1 + C} \frac{R - R_L}{Z(\infty) + R_L} \frac{R_L}{Z(\infty) + R_L} \frac{1}{1 + j\omega\tau^*}. \quad (26)$$

Consequently, the output noise temperature is:

$$T_{out}^{TF}(\omega) = \frac{|e_{TF}^*|^2}{k_B R_L} = \frac{4\theta^2 G}{I^2} \frac{C^2}{\left[1 + C \frac{R - R_L}{Z(\infty) + R_L}\right]^2} \frac{R_L}{[Z(\infty) + R_L]^2} \frac{1}{1 + (\omega\tau^*)^2}. \quad (27)$$

Using Eq. 17 this results in the following mixer noise:

$$T_m^{TF} = \frac{2\theta^2 G}{\alpha^2 P_{LO}}. \quad (28)$$

### Effective noise bandwidth.

An interesting consequence of Eqs. 24 and 28 is that whereas the  $T_m^J$  value increases at intermediate frequencies larger than  $(2\pi\tau_{\theta})^{-1}$ , the thermal fluctuation noise temperature does not depend on IF. Thus, the equivalent bandwidth of the mixer device is given by:

$$\Delta f = (2\pi\tau_{\theta})^{-1} \sqrt{1 + \frac{T_m^{TF}}{T_m^J}} \quad (29)$$

### Broken-line transition model.

For further analysis it is useful to simplify the model assuming that the  $R(T)$  characteristic of the bolometer has a broken-line shape [18] (see Fig. 2). Then, using a steady state heat balance equation for the electron temperature

$$AV(\theta^n - T^n) = P_{DC} + \alpha P_{LO}, \quad (30)$$

we can obtain  $G(\theta) = nAV\theta^{n-1}$ , where  $n$  is the material dependent constant ( $n = 4$  for Nb). Since  $\theta = T_c$  and  $R = R_n/2$  then  $C = 2P_{DC} / (nAVT_c^{n-1}\Delta T_c)$ .

One can see from Eqs. 24 and 28 that the increase of both  $P_{LO}$  and  $C$  leads to the decrease of the noise temperature. At the same time  $P_{DC}$  decreases since both  $\theta$  and  $T$  are fixed (see Eq. 30). The most favorable regime



of operation is when  $C = 1$ , which corresponds to  $P_{DC} = nAV T_c^{n-1} \Delta T_c / 2$ . To ensure this condition the applied LO power has to heat the device up to the temperature point  $\theta^* = T_c - \Delta T_c / 2$ , just below the superconducting transition edge (see Fig. 2). The LO power is then given by  $P_{LO} = \alpha^{-1} AV (T_c^n - T^n - nT_c^{n-1} \Delta T_c)$ . The I-U characteristic for this case is shown in Fig. 3.

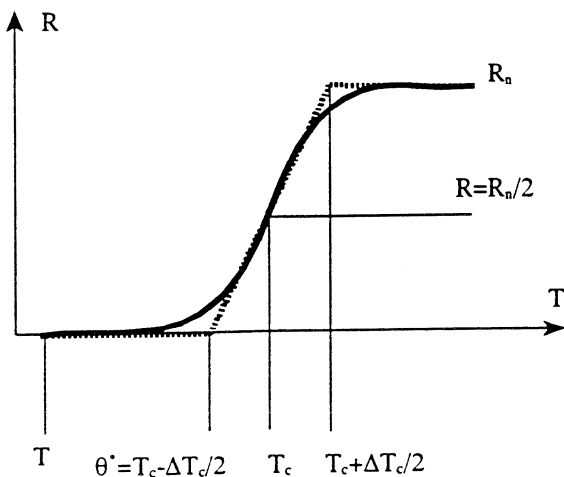

Fig. 2.  $R(T)$  curve and "broken-line transition".

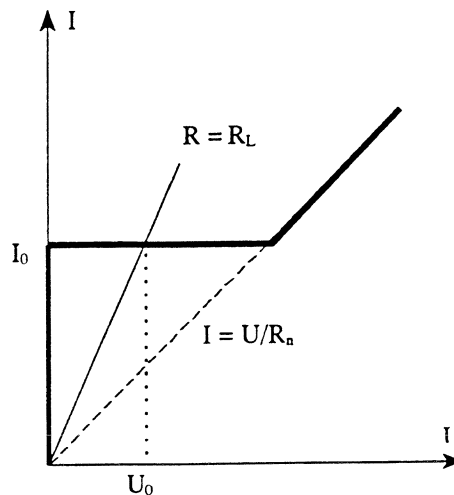

Fig. 3. Pumped I-U curve for  $C = 1$ .

Finally, we obtain

$$T_m^J = \frac{\alpha^{-1} n T_c^n \Delta T_c}{T_c^n - T^n - n T_c^{n-1} \Delta T_c} \quad \text{and} \quad T_m^{TF} = \frac{2 \alpha^{-1} n T_c^{n+1}}{T_c^n - T^n - n T_c^{n-1} \Delta T_c} \tag{31}$$

It is seen that a larger difference between  $T_c$  and  $T$  provides a lower noise temperature, therefore when  $T_c^n \gg T^n$  and the superconducting transition is very narrow ( $\Delta T_c \ll T_c$ ) the noise temperatures are given by

$$T_m^J = n \Delta T_c / \alpha \quad \text{and} \quad T_m^{TF} = 2 n T_c / \alpha \tag{32}$$

The noise bandwidth of the device is in turn given by

$$\Delta f = (2\pi \tau_\theta)^{-1} \sqrt{1 + \frac{2 T_c}{\Delta T_c}} \tag{33}$$

We would like to point out that the minimum noise temperature due to thermal fluctuation noise does not depend on the superconducting transition width, but  $\Delta T_c$  must be made very small in order to reach this minimum. For the particular case considered by Prober,  $P_{LO} = P_{DC} = G(T_c) \Delta T_c / 4$  Eq. 28 gives  $T_m^{TF} = 8 \alpha^{-1} T_c^2 / \Delta T_c$ , which is similar to the corresponding formula in [18].

The conversion gain can be given for the "broken-line transition" model using Eq. 18:

$$\eta(0) = \frac{\alpha}{n} \frac{T_c}{\Delta T_c} \frac{R_L}{R} \tag{34}$$

The apparent time constant  $\tau^*$  for the conversion gain is given by

$$\tau^* = \frac{\tau_\theta}{2} \left( 1 + \frac{R_L}{R} \right). \quad (35)$$

It is seen from Eqs. 34 and 35 that the increase of the ratio  $R_L/R$  can ensure a very large conversion gain,  $\eta(0) > 1$ , but along with this the gain bandwidth can degrade significantly. However, a gain as large as  $\eta(0) \approx 1$  can be obtained even if  $R_L = R$ , that also gives  $\tau^* \approx \tau_\theta$ . This is important if one wants to increase the gain bandwidth and, hereby reduce the noise contribution of IF circuit at higher intermediate frequencies. The contribution to the noise temperature from the mixer itself does not depend on IF load.

The estimations from Eqs. 32 and 33 for typical materials currently used for fabrication of hot electron mixers and  $\alpha = 1$  are presented in Table I. One can see that an excellent noise performance can be expected for both Nb and NbN superconducting HEB mixers.

Table I. Theoretical limits for the noise performance of HEB mixers.

Material	$T_c$ [K]	$\Delta T_c$ [K]	$n$	$T_m^J$ [K]	$T_m^{TF}$ [K]	$\tau_\theta$ [ns]	$\Delta f$ [GHz]
Nb	5	0.1	4	0.4	40	0.5 <sup>a</sup>	3.2
NbN	12	0.5	3.6	1.8	86	0.2 <sup>b</sup>	5.0

<sup>a</sup> These data are taken from [24] assuming the electron diffusivity to be  $1 \text{ cm}^2/\text{s}$ .

<sup>b</sup> We use the experimental data recently obtained in mixing experiments at 100 GHz [13–15] and at 300–350 GHz [11,16]. They are different from the results of  $\tau_{e-ph}$  measurements performed in equilibrium conditions in [25].

The most important formulas obtained above are summarized in Table II.

### *Related experiments.*

The HEB responsivity and impedance have been studied in [20] and [21] respectively. A good agreement with the frequency dependence given by Eqs. 11 and 15 has been obtained for Nb device placed in a strong magnetic field. The value of  $\tau_\theta$  has been studied as a function of  $P_{DC}$  and  $P_{LO}$ .

More recently the similar study has been performed for Nb HEB mixer at 20 GHz with no magnetic field applied [9]. The validity of Eq. 18 for conversion gain has been checked. Also Eq. 11 for impedance and Eq. 16a for the

Table II. Equation summary

Voltage responsivity	$S(\omega) = \frac{\alpha}{I} \frac{C}{1+C} \frac{R - R_L}{Z(\infty) + R_L} \frac{R_L}{Z(\infty) + R_L} \frac{1}{1 + j\omega\tau^*}$
Apparent time constant	$\tau^* = \frac{\tau_\theta}{1+C} \frac{R - R_L}{Z(\infty) + R_L}$
Impedance	$Z(\omega) = \frac{CR + Z(\infty)}{1-C} \frac{1 + j\omega\tau_0}{1 + j\omega\tau^-}$
Impedance time constants	$\tau^- = \frac{\tau_\theta}{1-C}, \tau_0 = \frac{\tau_\theta Z(\infty)}{Z(\infty) + CR}$
Conversion gain	$\eta(\omega) = 2\alpha C^2 \frac{RR_L}{[Z(\infty) + R_L]^2} \frac{1}{\left[1+C \frac{R - R_L}{Z(\infty) + R_L}\right]^2} \frac{1}{1 + (\omega\tau^*)^2}$
Johnson output noise temperature	$T_{out}^J(\omega) = \frac{4Z(\infty)R_L\theta}{[Z(\infty) + R_L]^2} \frac{1}{\left[1+C \frac{R - R_L}{Z(\infty) + R_L}\right]^2} \frac{1 + (\omega\tau_\theta)^2}{1 + (\omega\tau^*)^2}$
Thermal fluctuation output noise temperature	$T_{out}^{TF}(\omega) = \frac{4\theta^2 G}{I^2} \frac{C^2}{\left[1+C \frac{R - R_L}{Z(\infty) + R_L}\right]^2} \frac{R_L}{[Z(\infty) + R_L]^2} \frac{1}{1 + (\omega\tau^*)^2}$
Johnson mixer noise temperature	$T_m^J(\omega) = T_{out}^J(\omega)\eta(\omega) = \frac{2\theta P_{DC}}{\alpha^2 C^2 P_{LO}} \frac{Z(\infty)}{R} \left[1 + (\omega\tau_\theta)^2\right]$
Thermal fluctuation mixer noise temperature	$T_m^{TF} = \frac{2\theta^2 G}{\alpha^2 P_{LO}}$
Effective noise bandwidth	$\Delta f = (2\pi\tau_\theta)^{-1} \sqrt{1 + \frac{T_m^{TF}}{T_m^J}}$

apparent time constant were found to work well. Noise measurements indicated a device output noise temperature of about 50 K and SSB mixer noise temperature below 250 K. There are also a number of measurements done with a waveguide 100 GHz receiver [14,15] where a receiver noise temperature (DSB) has been measured to be  $\leq 1000$  K along with a 1 GHz bandwidth. Similar data have been obtained for quasi-optical (double-dipole antenna on substrate lens) receiver at 350 GHz [11]. The receiver noise temperature (DSB) was around 3000 K whereas a mixer noise temperature could be as small as 400 K. For outdiffusion cooled mixer recent experiments [10] indicated a noise temperature as low as 600 K along with about 2 GHz bandwidth.

Experiments with NbN devices revealed a physical phenomenon preventing a good mixer performance at higher IF. At temperatures  $T \ll T_c$  in the films longer than the thermal diffusion length the resistive state created by transport current is, usually, spatially non-uniform because of the normal domain formation. A significant fraction of the radiation power is absorbed in the normal metal parts of the film and then diffuses through the N-S boundaries in the film (domain edges), giving an indirect contribution to the bolometer response. The latter process slows down the relaxation process as whole which, moreover, can not be described by a single time constant [16]. As a result, the necessary LO power is determined by the smaller effective thermal conductivity for the slower process, similar to that given by Eq. 30. The fast process, responsible for mixing at higher IF, is thereby "underpumped". For instance, for a NbN HEB mixer made of  $\sim 20$  nm thick film, when pumping was done with 300–350 GHz radiation, a uniform resistive state appeared only when  $T = 7.5\text{--}8$  K whereas  $T_c = 9$  K [16]. However, even in this case the thermal fluctuation noise dominated, giving about 400 K SSB contribution to the mixer noise temperature [11]. The output mixer noise temperature has been measured as a function of IF. It has been found that the corresponding time constant agrees well with that for conversion gain. The value of the output noise temperature due to thermal fluctuations also agrees with Eq. 27. The Johnson noise contributed as little as 40 K, hence the effective noise bandwidth of the device given by Eq. 13 could be 2–2.5 GHz ( $\tau_\theta = 230$  ps). The influence of the domains can be hopefully reduced at higher radiation frequencies where the absorption of radiation is more uniform.

## V. Novel HEB devices

### *HEB exploring outdiffusion cooling.*

When the device length is made very short ( $L \ll \sqrt{D \tau_{e-ph}}$ ) then the diffusion of hot electron into the contacts becomes more effective cooling mechanism than the electron-phonon interaction. This mechanism has been suggested for terahertz HEB mixer by Prober [18] to solve the problem of narrow band in Nb devices. Recent experiments [10] have demonstrated that as wide as 2 GHz bandwidth can be attained if the device length is made 0.2–0.3  $\mu\text{m}$ . The efficiency of such cooling mechanism in nanoscale metal structures has been recently demonstrated in [26]. The crossover between the electron-phonon energy relaxation and the electron diffusion transport was experimentally observed in  $\text{Au}_{60}\text{Pd}_{40}$  alloy wires at temperatures below 1.5 K.

It is likely that this type of distributed HEB can, nevertheless be considered as lumped to some extent. Since electron-electron inelastic time  $\tau_{ee}$  for similar Nb films at 5 K is  $\sim 20$  ps [27,28] the electron temperature relaxation length  $l_e = \sqrt{D \tau_{ee}} = 40\text{--}70$  nm ( $D = 1\text{--}3$   $\text{cm}^2 \text{s}^{-1}$  [24,29]) is shorter than the sample length. This allows to describe such type of HEB to some extent in terms of electron temperature using the noise theory given above. Numerical modeling [30] shows that the relaxation of electron temperature can be well approximated by single time constant  $\tau_{diff} \approx (L/4)^2/D$ . Under such conditions the main contribution to the mixer noise temperature is given by Eq. 28 where  $G = c_e V / \tau_{diff}$ . However, because of the distributed heat link a modification of the thermal fluctuation noise has to be taken into account [23]. If thermal conductivity  $G$  relates to the highest temperature point ( $T_c$ ), the noise temperature given by Eq. 28 should be multiplied by factor

$$\Gamma = \frac{\int_T^{T_c} \left[ \frac{t\chi(t)}{T_c\chi(T_c)} \right]^2 dt}{\int_T^{T_c} \frac{\chi(t)}{\chi(T)} dt}, \quad (36)$$

where  $\chi(T)$  is the thermal conductivity of the film. Considering that the thermal conductivity in the resistive state of the bolometer is close to that for normal metal ( $\chi \propto T$ ). The  $\Gamma$  value can be obtained in the following form:

$$\Gamma = \frac{2}{3} \frac{T_c^3 - T^3}{T_c T_c^2 - T^2}. \quad (37)$$

The largest reduction of noise  $\Gamma = 2/3$  is achieved if  $T \ll T_c$ .

### *High- $T_c$ mixer.*

Thin films made of high- $T_c$  superconductors are interesting for terahertz HEB mixer applications since they offer a very short electron–phonon relaxation time  $\sim 10^{-12}$  s. For the first time this fact was emphasized in [31] and more thoroughly studied in a series of papers [32–34]. Recently the fast response of picosecond duration to optical and FIR laser pulses has been found in  $\text{YBa}_2\text{Cu}_3\text{O}_{7-\delta}$  thin ( $d < 100$  nm) films. The data both of kinetic inductance response and pure resistive response have been obtained [35–41]. The latter can be reasonably well described in terms of hot–electron phenomena in high- $T_c$  film [41]. The most essential difference from the low temperature case is that the non–equality  $c_e \gg c_p$  does not hold no longer if the working temperature is about 90 K. According to the literature data on  $\text{YBaCuO}$  phonon and electron heat capacities  $c_p \approx (25\text{--}30)c_e$ . In such case the heating of lattice is unavoidable at low IF. To describe the situation more properly the heat balance equation (Eq. 1) has to be supplemented with a similar equation for the phonon temperature  $T_p$  which now is different from bath temperature  $T$ . The characteristics of the high- $T_c$  HEB can be obtained from the following equations:

$$c_e V \frac{\partial \theta}{\partial t} = -\Pi(\theta, T_p) + IU + \alpha P_{\text{rad}} \quad (38)$$

$$c_p V \frac{\partial T_p}{\partial t} = -\Psi(T_p, T) + \Pi(\theta, T_p) \quad (38a)$$

For the case when both functions  $\Pi$  and  $\Psi$  can be linearized, i.e.  $\Pi(\theta, T_p) = c_e(\theta - T_p)/\tau_\theta$  and  $\Psi(T_p, T) = c_p(T_p - T)/\tau_{es}$  the solution for the alternating part of electron temperature  $\Delta\theta$  was given in [19]:

$$\Delta\theta = \alpha P_{\text{rad}} \frac{\tau_{e-ph} + (c_e/c_p)\tau_{es}}{c_e} \frac{1 + j\omega\tau_\phi}{(1 + j\omega\tau_1)(1 + j\omega\tau_2)}. \quad (39)$$

Three time constants in Eq. 38 can be found as follows:

$$\tau_{1,2}^{-1} = \tau_{+,-}^{-1} = \frac{1}{2\tau} \left[ 1 \pm \sqrt{1 - 4 \frac{\tau^2}{\tau_{es} \tau_{e-ph}}} \right], \tau^{-1} = \tau_{es}^{-1} + \tau_{e-ph}^{-1} \left( c_e / c_p + 1 \right), \text{ and } \tau_{\phi}^{-1} = \tau_{es}^{-1} + \tau_{e-ph}^{-1} c_e / c_p. \quad (40)$$

Since for YBaCuO films  $\tau_{e-ph}$  is quite short then as a rule  $\tau_{es} \gg \tau_{e-ph}$  even for thin films. This condition together with the non-equality  $c_p \gg c_e$  allows to simplify Eq. 38:

$$\Delta\theta = \alpha P_{rad} \frac{\tau_{e-ph} + (c_e/c_p) \tau_{es}}{c_e} \frac{1 + j\omega \tau_{e-ph} c_p / c_e}{(1 + j\omega \tau_{es})(1 + j\omega \tau_{e-ph})}. \quad (41)$$

Such frequency dependence has been recently demonstrated in optical mixing experiment ( $\lambda = 1.55 \mu\text{m}$ ) performed up to IF = 18 GHz [17] (see Fig. 4). It is seen from the modelled curves that a decrease of the film thickness makes the frequency dependence more flat which is useful for reducing of the conversion loss at higher IF's.

A simple way to estimate the mixer noise temperature is the introduction of frequency dependent thermal conductivity:

$$G_{\omega}^{-1} = \frac{\tau_{e-ph} + (c_e/c_p) \tau_{es}}{c_e} \frac{1 + j\omega \tau_{e-ph} c_p / c_e}{(1 + j\omega \tau_{es})(1 + j\omega \tau_{e-ph})} \quad (42)$$

and its use at high IF's of interest ( $\tau_{e-ph}^{-1} c_e / c_p \ll \omega < \tau_{e-ph}^{-1}$ ). Within this region ("second plateau") the thermal conductivity can be reduced to

$$G_2 = \frac{c_e^2 \tau_{es}}{(\tau_{e-ph} + c_e \tau_{es} / c_p) \tau_{e-ph} c_p}. \quad (43)$$

At the same time the self-heating parameter  $C$  is determined by the thermal conductivity taken at dc:

$$G_0 = \frac{c_e}{\tau_{e-ph} + (c_e/c_p) \tau_{es}}. \quad (44)$$

For example, for thin films used in [41] ( $d = 60 \text{ nm}$ ) on MgO substrates  $\tau_{es} = 2 \text{ ns}$ ,  $\tau_{e-ph} = 1.5\text{-}2 \text{ ps}$  giving  $G_0 \approx 40G_2$ .

$P_{DC}$  and  $P_{LO}$  can be estimated as

$$P_{LO} = \frac{g_e g_p}{g_e + g_p} (T_c - T) \quad \text{and} \quad P_{DC} = \frac{g_e g_p}{g_e + g_p} \frac{\Delta T_c}{2}, \quad (45)$$

where  $g_e \equiv c_e / \tau_{e-ph}$ ,  $g_p \equiv c_p / \tau_{es}$ . With typical practically interesting parameters  $T = 77 \text{ K}$ ,  $T_c = 90 \text{ K}$  we obtain the "conversion gain at dc"

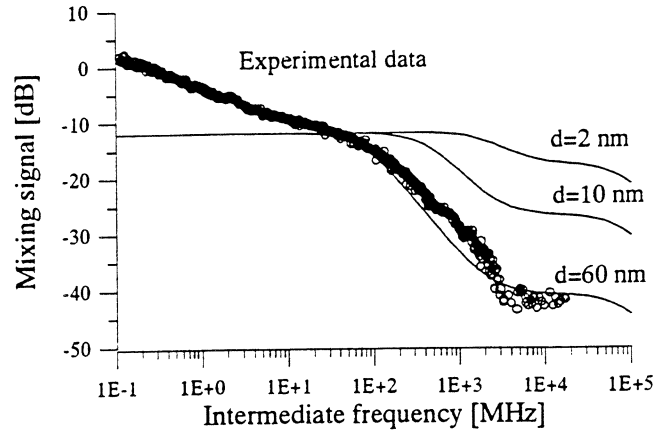

Fig. 4. Optical mixing data obtained with  $YBa_2Cu_3O_{7-x}$  thin film [17] and fitting (solid lines) to two-temperature model with different film thickness'. The "excessive" signal below 50 MHz is because of the heat diffusion in the substrate.

$$\eta_{DC} = \frac{P_{Lo}}{2P_{DC}} = \frac{T_c - T}{\Delta T_c} \approx 20 \quad (46)$$

and thermal fluctuation noise temperature

$$T_m^{FL} \approx \frac{2T_c^2}{T_c - T} \approx 800K. \quad (47)$$

To estimate the Johnson noise contribution one can use the conversion gain within "second plateau"

$$\eta_2 = \frac{T_c - T}{\Delta T_c} \frac{\tau_{e-ph} C_p}{\tau_{es} C_e} \approx 0.25 \quad (48)$$

and, finally, the noise temperature is given  $T_m^J = T_c / \eta_2 = 360K$ .

## Conclusion

In conclusion, we have derived the analytic expressions describing an ideal hot-electron bolometer mixer performance. It has been shown that the noise temperature limit is determined by the thermal fluctuations and SSB noise temperature can as low as several  $T_c$ 's. An equivalent noise bandwidth can be theoretically very wide even for the devices made of material with a relatively long electron-phonon relaxation time. The bandwidth depends on the superconducting transition width (Johnson noise contribution) and also on the contribution of IF amplifier. Even for presently available Nb films the bandwidth set by the intrinsic noises is estimated to be about a few GHz. The present theory has passed a partial experimental verification and, hopefully, can be useful for description and prediction of the characteristics of various hot-electron mixers.

## Acknowledgment

We thank E. Gershenzon and G. Gol'tsman for interest to this research, D. Prober and K.S. Yngvesson for stimulating discussions on the origin of HEB noises. BSK is grateful to E. Kollberg for the hospitality at Chalmers University of Technology and numerous discussions on the mixing mechanism in bolometric devices. The cooperation with H. Ekström was very fruitful and stimulated the formulating of many statements in this paper.

This research was made possible in part by Grant No. NAF000 from the International Science Foundation. We also acknowledge the support from Russian Council on High- $T_c$  Problem under Grants No. 93169 and No. 94043.

## References

- [1] G. de Lange, C.E. Honingh, J.J. Kuipers, H.H.A. Schaeffer, R.A. Panhuyzen, T.M. Klapwijk, H. van de Stadt, and M.M.W.M. de Graauw, "Heterodyne Mixing with Nb Tunnel Junctions Above the Gap Frequency," *Appl. Phys. Lett.*, vol. 64(22), pp. 3039-3041, 30 May 1994.
- [2] J. Zmuidzinas, H.G. LeDuc, J.A. Stern, and S.R. Cypher, *IEEE Trans. on Microwave Theory and Techniques*, vol. 42, p. 698, 1994.
- [3] P. Febvre, W.R. McGrath, P. Batelaan, B. Bumble, H.G. LeDuc, S. George, and P. Feautrier, "A Low-Noise Receiver Measured from 480 GHz to 650 GHz Using Nb Junctions with Integrated RF Tuning Circuits," *Int. J. IR and MM Waves*, vol. 15(6), pp. 943-965, June 1994.
- [4] K.-F. Schuster, A.I. Harris, and K.H. Gundlach, "A 691 GHz Receiver for Radio Astronomy," *Int. J. IR and MM Waves*, vol. 14(10), pp. 1867-1887, October 1993.
- [5] H. Rothermel, K.H. Gundlach, and M. Voss, "A 350 to 700 GHz Open Structure SIS Receiver for SubMM. Radioastronomy," *Colloque C6 Supplement au J. de Physique III*, vol. 4, pp. 267-272, June 1994.
- [6] J.W. Kooi, C.K. Walker, H.G. LeDuc, P.L. Schaffer, T.R. Hunter, D.J. Benford, and T.G. Phyllips, "A Low Noise 665 GHz SIS Quasi-Particle Waveguide Receiver," *IEEE Trans. on Microwave Theory and Techniques*, vol. 42, p. 750, 1994.
- [7] J. Zmuidzinas, N.G. Ugras, D. Miller, M. Gaidis, H.G. LeDuc, and J.A. Stern, "Low-Noise Slot Antenna SIS Mixers," *IEEE Trans. on Appl. Supercond.*, in press.
- [8] E.M. Gershenzon, G.N. Gol'tsman, I.G. Gogidze, Y.P. Gusev, A.I. Elant'ev, B.S. Karasik, and A.D. Semenov, "Millimeter and submillimeter range mixer based on electronic heating of superconducting films in the resistive state," *Sverhprovodimost' (KIAE)*, vol. 3(10), pp. 2143-2160, October 1990 [*Sov. Phys. Superconductivity*, vol. 3(10), pp. 1582-1597, 1990].
- [9] H. Ekström, B.S. Karasik, E. Kollberg, and K.S. Yngvesson, "Investigation of a superconducting hot electron mixer," Proc. of the Fifth Int. Symp. on Space Terahertz Technology (May 10-12, 1994, Ann Arbor, Michigan), pp. 169-188; "Conversion gain and noise of niobium superconducting hot-electron-mixers," *IEEE Trans. on Microwave Theory and Techniques*, in press.
- [10] A. Skalare, W.R. McGrath, B. Bumble, H.G. LeDuc, P.J. Burke, A.A. Verheijen, and D.E. Prober, "A heterodyne receiver at 533 GHz using a diffusion-cooled superconducting hot electron bolometer mixer," *IEEE Trans. on Appl. Supercond.*, in press.



- [11] H. Ekström and B. Karasik, "Electron temperature fluctuation noise in hot-electron superconducting mixer," *Appl. Phys. Lett.*, in press; H. Ekström, B. Karasik, E. Kollberg, G. Gol'tsman, and E. Gershenson, "350 GHz NbN hot electron bolometer mixer," *this issue*.
- [12] F. Arams, C. Allen, B. Peyton, and E. Sard, "Millimeter mixing and detection in bulk InSb," *Proc. IEEE*, vol. 54, pp. 308-318, 1966.
- [13] A. Dzardanov, H. Ekström, E. Gershenson, G. Gol'tsman, S. Jacobsson, B. Karasik, E. Kollberg, O. Okunev, B. Voronov, and S. Yngvesson, "Hot-electron superconducting mixers for 20–500 GHz operation," *Proc. SPIE*, vol. 2250, pp. 236-238, 1994.
- [14] O. Okunev, A. Dzardanov, H. Ekström, S. Jacobsson, E. Kollberg, G. Gol'tsman, and E. Gershenson, "NbN hot electron waveguide mixer for 100 GHz operation," *Proc. of the 5th Int. Symp. on Space Terahertz Technology* (May 10–12, 1994, Ann Arbor, Michigan), pp. 214-224.
- [15] G.N. Gol'tsman, B.S. Karasik, O.V. Okunev, A.L. Dzardanov, E.M. Gershenson, H. Ekström, S. Jacobsson, and E. Kollberg, "NbN hot electron superconducting mixers for 100 GHz operation," *IEEE Trans. on Appl. Supercond.*, in press.
- [16] B.S. Karasik, G.N. Gol'tsman, B.M. Voronov, S.I. Svechnikov, E.M. Gershenson, H. Ekström, S. Jacobsson, E. Kollberg, and K.S. Yngvesson, "Hot electron quasi-optical NbN superconducting mixer," *IEEE Trans. on Appl. Supercond.*, in press.
- [17] M. Lindgren, M.A. Zorin, A.V. Trifonov, M. Danerud, D. Winkler, B.S. Karasik, G.N. Gol'tsman, and E.M. Gershenson, "Optical mixing in a patterned  $\text{YBa}_2\text{Cu}_3\text{O}_{7-x}$  film," *Appl. Phys. Lett.*, vol. 65(26), pp. 3398-3400, 26 December 1994.
- [18] D.E. Prober, "Superconducting terahertz mixer using a transition-edge microbolometer," *Appl. Phys. Lett.* vol. 62(17), pp. 2119-2121, 26 April 1993.
- [19] N. Perrin and C. Vanneste, "Response of superconducting films to a periodic optical irradiation," *Phys. Rev.* vol. B28, pp. 5150-5159, 1 November 1983.
- [20] E.M. Gershenson, G.N. Gol'tsman, A.I. Elant'ev, B.S. Karasik, and S.E. Potoskuev, "Intense electromagnetic radiation heating of electrons in the resistive state," *Fiz. Nizk. Temp.* vol. 14(7), pp. 753-763, July 1988 [*Sov. J. Low Temp. Phys.*, vol. 14(7), pp. 414-420, 1988].
- [21] A.I. Elant'ev and B.S. Karasik, "Effect of high frequency current on Nb superconducting film in the resistive state," *Fiz. Nizk. Temp.*, vol. 15(7), pp. 675-683, July 1988 [*Sov. J. Low Temp. Phys.*, vol. 14(7), pp. 379-383, July 1988].
- [22] J.C. Mather, "Electrical self-calibration of nonideal bolometer," *Appl. Opt.* vol. 23(18), pp. 3181-3183, 15 September 1982.
- [23] J.C. Mather, "Bolometer noise: nonequilibrium theory," *Appl. Opt.* vol. 21(6), pp. 1125-1129, 15 March 1982.
- [24] E.M. Gershenson, M.E. Gershenson, G.N. Gol'tsman, A.M. Lyul'kin, A.D. Semenov, and A.V. Sergeev, "Electron-phonon interaction in ultrathin Nb films," *Zh. Eksp. Teor. Fiz.*, vol. 97, pp. 901, 1990 [*Sov. Phys. JETP*, vol. 70, pp. 505-511, March 1990].

- [25] Yu.P. Gousev, G.N. Gol'tsman, A.D. Semenov, E.M. Gershenzon, R.S. Nebosis, M.A. Heusinger, and K.F. Renk, "Broadband ultrafast superconducting NbN detector for electromagnetic radiation," *J. Appl. Phys.*, vol. 75, pp. 3695-3697, April 1994.
- [26] M. Kanskar and M.N. Wybourne, "Crossover between dissipative and nondissipative electron transport in metal wires," *Phys. Rev. Lett.*, vol. 73(15), pp. 2123-2126, 10 October 1994.
- [27] B.J. Dalrymple, S.A. Wolf, A.C. Enrich, and D.J. Gillespie, "Inelastic electron lifetime in niobium films," *Phys. Rev.*, vol. B33(11), pp. 7514-7519, 1 June 1986.
- [28] M.E. Gershenzon, V.N. Gubankov, and Yu.E. Zhuravlev, "Quantum effects in two-dimensional films of superconductors at  $T > T_c$ ," *Zh. Exp. Teor. Fiz.*, vol. 85(1), pp. 287-298, July 1983.
- [29] J.W.P. Hsu and A. Kapitulnik, "Superconducting transition, fluctuation, and vortex motion in two-dimensional single-crystal Nb film," *Phys. Rev.*, vol. B45(9), pp. 4819-4835, March 1992.
- [30] D. Prober, private communication.
- [31] E.M. Gershenzon, M.E. Gershenzon, G.N. Gol'tsman, B.S. Karasik, A.D. Semenov, A.V. Sergeev, "Light-induced heating of electrons and the time of the inelastic electron-phonon scattering in the YBaCuO compound", *JETP Lett.*, vol. 46(7), pp. 226-228, 1987.
- [32] E.M. Gershenzon, G.N. Gol'tsman, I.G. Goghidze, A.D. Semenov, and A.V. Sergeev, "Processes of electron-phonon interaction in thin YBaCuO films," *Physica C*, vol. 185-189, pp. 1371-1372, 1991.
- [33] A.D. Semenov, G.N. Gol'tsman, I.G. Goghidze, A.V. Sergeev, E.M. Gershenzon, P.T. Lang, and K.F. Renk, "Subnanosecond photoresponse of a YBaCuO thin film to infrared and visible radiation by quasiparticle induced suppression of superconductivity," *Appl. Phys. Lett.*, vol. 60(7), pp. 903-906, 1992.
- [34] E.M. Gershenzon, G.N. Gol'tsman, A.D. Semenov, and A.V. Sergeev, "Mechanism of picosecond response of granular YBaCuO films to electromagnetic radiation," *Solid State Commun.*, vol. 76(4), pp. 493-496, 1990.
- [35] M. Johnson, "Nonbolometric photoresponse of YBCO film," *Appl. Phys. Lett.*, vol. 59(11), pp. 1371-1373, 1991.
- [36] L. Shi, G.L. Huang, C. Lehane, J.P. Zheng, and H.S. Kwok, "Temporal relaxation measurements of photoinduced nonequilibrium in superconductor," *Appl. Phys. Lett.*, vol. 61(4), pp. 489-491, 1992.
- [37] N. Bluzer, "Temporal relaxation of nonequilibrium in Y-Ba-Cu-O measured from transient photoimpedance response," *Phys. Rev.*, vol. B44(18), pp. 10222-10233, 1991.
- [38] F.A. Hegmann, J.S. Preston, "Origin of the fast photoresponse of epitaxial  $\text{YBa}_2\text{Cu}_3\text{O}_{7-x}$  thin films," *Phys. Rev.*, vol. B48(21), pp. 16023-16039, 1993.
- [39] F.A. Hegmann, R.A. Hughes, J.S. Preston, "Picosecond photoresponse of epitaxial  $\text{YBa}_2\text{Cu}_3\text{O}_{7-x}$  thin films," *Appl. Phys. Lett.*, vol. 64(23), pp. 3172-3174, 1994.
- [40] A. Ghis, S. Pfister, J.C. Villegier, M. Nail, and J.P. Maneval, "Ultra fast non bolometric photoresponse of  $\text{YBa}_2\text{Cu}_3\text{O}_{7-x}$  thin films," *IEEE Trans. Appl. Superconductivity*, vol. 3(1), pp. 2136-2139, 1993.
- [41] M. Lindgren, V. Trifonov, M. Zorin, M. Danerud, D. Winkler, B.S. Karasik, G.N. Gol'tsman, and E.M. Gershenzon, "Transient resistive photoresponse of  $\text{YBa}_2\text{Cu}_3\text{O}_{7-x}$  films using low power 0.8 and 10.6  $\mu\text{m}$  laser radiation," *Appl. Phys. Lett.*, vol. 64(22), pp. 3036-3038, 30 May 1994.