

MEASUREMENT AND STUDY OF THE EMBEDDING IMPEDANCE PRESENTED BY
THE WHISKER ANTENNA OF A SCHOTTKY DIODE CORNER CUBE MIXER

C M Mann,** T Suzuki,* J J Chang,** T Nozokido,** Y Kuwano* and
K Mizuno.*

ABSTRACT

A 250X scale model of a Schottky diode corner cube mixer designed for operation in the terahertz region has been built and tested. It has been successfully used to measure the embedding impedance presented to the diode at the whisker tip and also determine the impedance of the whisker antenna itself. The results are presented and their relevance to the performance of an operational mixer is considered.

* Research Institute of Electrical Communication
Tohoku University, Sendai, 980, Japan

** Photodynamics Research Centre,
The Institute of Physical and Chemical Research (Riken)
19-1399 Aza-Koeji, Naga-Machi, AobaKu, 980 Sendai, Japan.

INTRODUCTION

The technique of microwave limb sounding from space as implemented by the Upper Atmosphere Research Satellite (UARS) has been shown to be an extraordinarily powerful tool for the study of the Earth's atmosphere. The technique can be further enhanced if the observational frequency is raised, largely because of the increased strength of the signal. With the advent of NASA's and ESA's future Earth Observing Systems (EOS), impetus has now been given to the area of submillimetre wave devices to take full advantage of this fact.

This research area has been of interest to radio astronomers, plasma physicists, molecular spectroscopists and atmospheric researchers. Due to the fabrication difficulties associated with waveguide based devices at these frequencies, the emphasis has mainly been placed on mixers making use of an open or quasi-optical structure. Of these the most studied by far has been the "corner cube" mixer. The basic layout of a typical corner cube mixer is shown in figure 1.

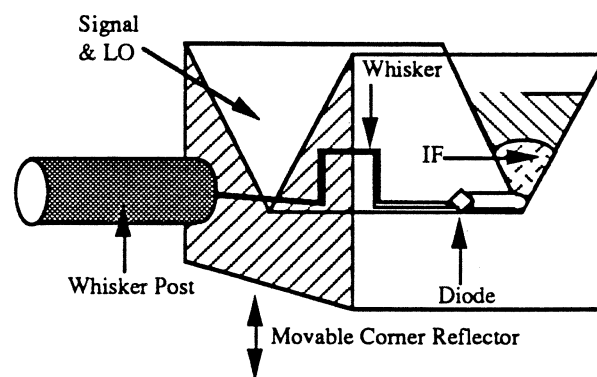

fig 1

Such mixers are comparatively easy to physically realise compared to their waveguide equivalent but such a simple format has its associated disadvantages. From a performance perspective the most obvious is their relatively poor coupling efficiency but this is usually acceptable for most uses and is somewhat compensated for by the lower losses in the signal path. Indeed excellent performance has been obtained by various researchers using designs incorporating subtle variations of the basic concept. For space applications, however, most of the designs in current use have one serious flaw which is the need for the contact to the diode to be made via a long whisker. This is necessary because the whisker not only forms the electrical contact to the diode but also forms the main antenna element. It is usually four wavelengths (4λ) at the signal frequency in order for the coupling efficiency between the mixer and the input beam to be optimised, although recent examinations report that shorter whiskers may be appropriate^{1,2}. This in itself would not be a problem if the diodes that are to be contacted were much larger than those required at terahertz frequencies ($\approx 0.5\mu\text{m}$ in diameter). Only the smallest of whisker tips can be used to contact the diode anode. As the whisker can be anything from $6\text{-}50\mu\text{m}$ in diameter it represents a large mass with respect to the whisker tip dimensions. In order to visualise the scale of this physical mismatch it is useful to consider the dimensions of the scaled whisker in our model. For the thickest whisker investigated ($50\mu\text{m}$ in diameter), whilst the 250X scaled whisker tip is represented by a piece of wire 0.1mm in diameter, the whisker itself is made from copper pipe that is 13mm in diameter and is over one metre in length. It is not surprising therefore that in real life once a contact to a diode has been made, the mixer has to be treated extremely carefully for the contact to stay intact. The chances of such a structure reliably surviving the vibration and

thermal environmental tests required for space flight are probably minimal. The rigours of space qualification should not be confused with those experienced in an astronomical receiver or during an airborne experiment. A device intended for space flight not only has to survive the qualification procedure, the rigours of launch but once in space has to survive for the entire duration of the mission in a stable condition and of course must **never** fail. For NASA's EOS programme the expected mission life time is 5 years. The format of the device will almost certainly have to be altered in some way in order for the corner cube to be considered a viable option.

The first part of this report therefore examines the part played by the whisker in the operation of the corner cube mixer to determine as to what extent the structure can be modified to make it more rugged. Secondly, the embedding impedances measured are used in conjunction with a computer analysis to assess the overall effect of the modifications on the mixers performance.

SCALE MODELLING OF THE CORNER CUBE MIXER

Whisker Antenna Impedance

The corner cube mixer was to be examined using a technique similar to that described by Eisenhart and Khan³. A HP8510C network analyser having a maximum operating frequency in coaxial line of 20GHz was available to make the measurement. For full frequency coverage a 250X model was required. Because a complete model would have been too large a 50X model of just the whisker post arrangement was first considered. This model could be examined only to a scaled frequency of 800GHz but it was hoped that this would be sufficient in also approximating the whisker posts effect at higher frequencies. This proved to be the case and it was then possible to ignore most of the whisker posts structure. The complete 250X mixer model then took the form shown in figure 2. The whisker antenna impedance is the characteristic impedance of whisker antenna minus the effect of it's tip.

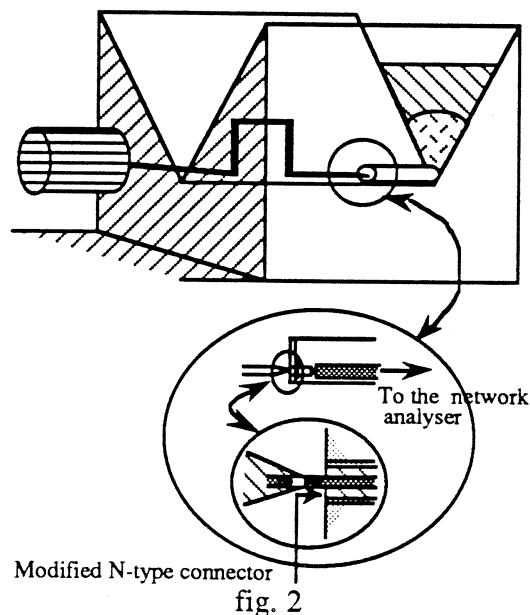

To measure the thickest whisker antenna's impedance it was necessary to make a simple 50Ω transformer to dimensionally match the N-type connector to the 13mm diameter scaled whisker. The signal could then be launched directly into the whisker antenna. The whisker

antenna impedance was found to be much lower than that measured at the whisker tip (30 - 50 Ω versus 90 - 120 Ω). The same procedure was carried out for other whisker diameters and the results are plotted in fig 3.

For tuning purposes it would be useful if the diode embedding impedance could be altered by varying the whisker dimensions. The easiest of these to change in real life would be the length of the whiskers first section. This was tried in the model. It was found that this could be altered with no effect on the impedance measured at the end of the 50 Ω transformer. In order to understand this the model was again examined in the time domain and it was found that the reflections from the bend were down at the -20dB level. This was not true if the first bend was very abrupt. Provided the first bend was of the order of $\approx\lambda/4$ in radius the active part of the antenna was limited to the length of whisker between the tip and the first bend. This has also been found by Matrese and Evenson⁴. The impedance could however be changed if the whisker was terminated too soon after the bend. If this distance was several wavelengths or more the final termination had no resultant effect on the embedding impedance at the diode. It was therefore apparent that the full whisker was not required for normal mixer operation and could be replaced by a simple right angle bend with no resultant loss of performance.

Whisker Antenna Impedance as a Function of Wire Diameter

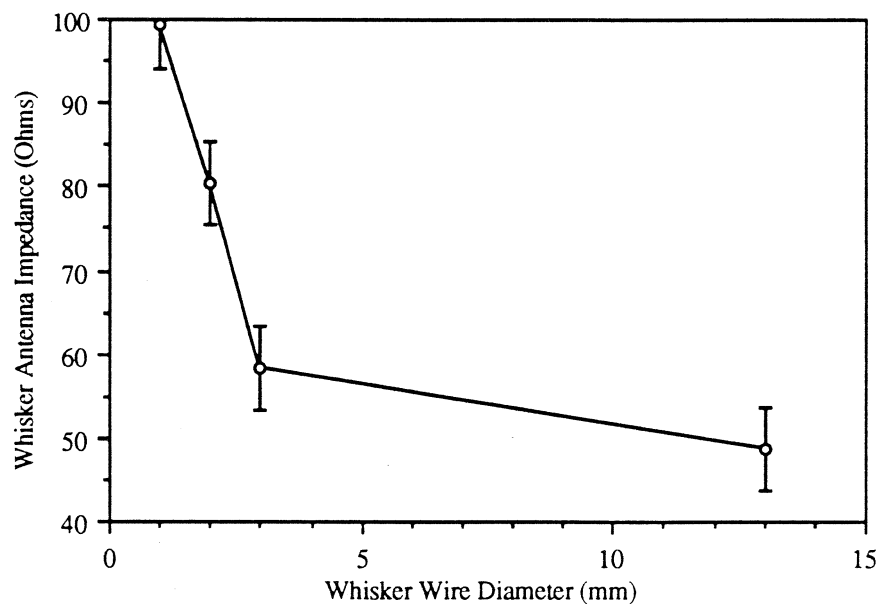

fig 3

The antenna appeared to be working as expected. The presence of the main lobe and side lobes could be established in a crude manner by placing a small metallic disc in the field and observing the magnitude of the reflection in the time domain.

Whisker Tip Impedance

This impedance was rather more difficult to measure than that of the whisker antenna itself. The main reason for this was that even for a scaling factor of 250 times, the diameter of the whisker tip was still only 0.1mm. Because of this an airline structure was used for the transition between the N-type connector and the scaled whisker tip. It was not possible to

machine a scaled version of the tip directly, instead a short length of wire (2mm) of the appropriate diameter was soldered between the whisker tip and the N-type connector pin. It was then possible to vary the effective whisker tips diameter very accurately. By using this arrangement it was possible to represent the true physical form of the whisker. The whisker could be reconnected easily in a reproducible manner, the details of the arrangement are shown in figure 4. It should be noted that for all results the distance between the whisker and antenna apex was set at 1.2λ for the scaled frequency corresponding to 1.4THz. Changing this parameter for each frequency would have made the measurement time consuming and laborious. In addition, the small change resulting in the diode embedding impedance could not have been easily resolved using this technique.

Different wire thicknesses corresponding to different tip diameters were tried for a range of whisker diameters.

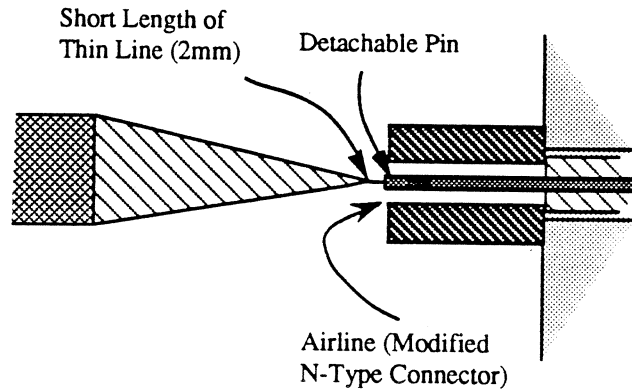

fig 4

The combined results are shown in figure 5. The parameters plotted are the real component of the normalised tip impedance versus the normalised tip diameter and are defined as the following:-

$$Z_{\text{norm}} = \frac{Z_{\text{tip}}}{Z_{\text{ant}}} \quad \dots 1$$

Where:-

- Z_{norm} = Real component of the normalised tip impedance.
- Z_{tip} = Real component of whisker tip impedance.
- Z_{ant} = Real component of whisker antenna impedance.

$$D_{\text{norm}} = \frac{D_{\text{tip}}}{D_{\text{whsr}}} \quad \dots 2$$

Where:-

- D_{norm} = Normalised tip diameter.
- D_{tip} = Diameter of the whisker tip.
- D_{whsr} = Diameter of the whisker.

The reactive component of the embedding impedance was not considered as it's magnitude was always less than 50Ω and the technique was not deemed accurate enough to state the measured value reliably down at this level. The plot shows the effect of the tip diameter on the diode embedding impedance for all frequencies. For the thickest whisker wire, the cone section at the whisker tip represents a considerable fraction of a wavelength at the signal

frequency. This represents a section of non uniform transmission line, the input to which is the high impedance ($\approx 200\Omega$) of the whisker tip itself.

Normalized Whisker Tip Impedance versus Normalized Tip Diameter

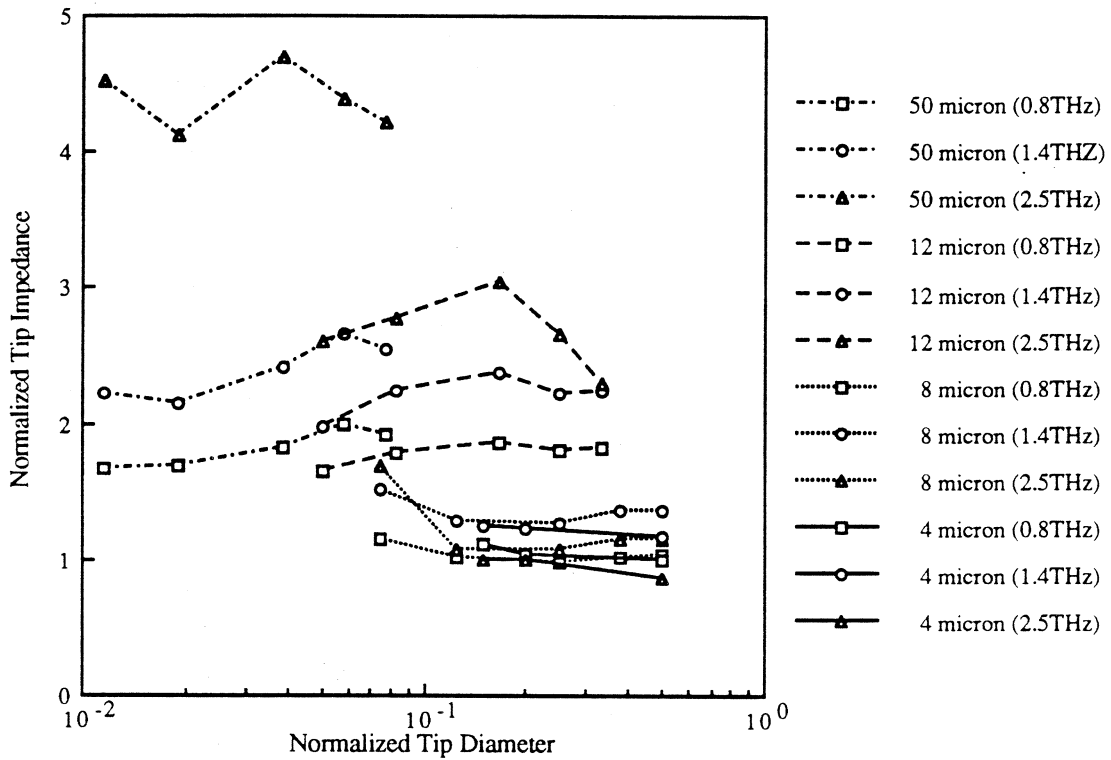

fig 5

Whisker Tip Impedance vs Frequency

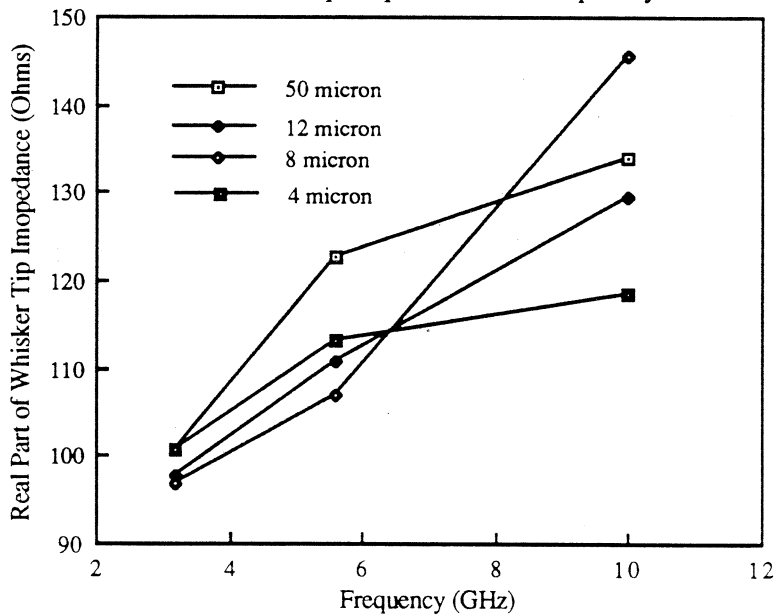

fig 6

The effect of this is to transform the lower impedance of the whisker antenna to some intermediate value. For thinner whiskers this is not the case. The geometry associated with the whisker etching process results in a much shorter cone section. Consequently the signal does not see the short length of high impedance line at the whisker tip, instead only that of the whisker antenna. The normalised impedance of the whisker tip therefore approaches the value 1.0 for successively thinner whiskers. For the typical whisker diameters currently in common use the embedding impedance is found to be approximately $120 \pm 20 \Omega$. The embedding impedance presented to the diode for different diameters of whisker wire is shown in figure 6. The diameter of the whisker tip is the same for all measurements ($0.6 \mu\text{m}$). It can be seen that even though the characteristic impedances for different thickness whisker antennae vary substantially (from $\approx 30 - 100 \Omega$, fig 3), the impedance measured at the whisker tip is relatively similar. For the $50 \mu\text{m}$ whisker antenna the embedding impedance at the diode is over four times that of the whisker antenna characteristic impedance. This effect can presumably be neglected for lower frequencies in the millimetre region where the wavelength is considerably larger than the whisker tips length.

COMPUTER MODELLING

In order to further understand mixer operation a computer model has been used. The program is a modified version of the original by P. H. Siegel et al⁵ and allows for the optimisation of conversion loss and noise performance as a function of LO power and DC bias. The IF port is always assumed conjugate matched.

Whilst the computer model does not take account of additional effects that may be present at terahertz frequencies (i.e. plasma resonance, surface loss etc..) it has been used with some success at lower frequencies⁷ and does provide an approximate guideline with regard to expected performance. Also, like the scale modelling it does give insight to the effects of circuit adjustment, for instance, embedding impedance and diode parameters. In this way it is possible to assess the overall action of each parameter on the mixers performance so as to establish tuning trends which can then be used to optimise the device in an understandable manner.

The diode embedding impedances obtained from the scale model were input into the computer program along with values for the diode parameters (table I). These were obtained from well known formulas but measured parameters from actual diodes were used as a reference ($0.4 \mu\text{m}$ diameter with an epi-layer thickness of 800 \AA).

Local oscillator frequency	1.4 THZ
Intermediate frequency	1.0 GHz
Mixer operating temperature	300 K
Diode reverse saturation current	$7.3 \cdot 10^{-19}$ A
Diode capacitance at zero bias	0.3 fF
Diode built in potential	0.96 V
Diode capacitance law exponent	0.5
Diode ideality factor	1.08
Diode series resistance at DC	83.3Ω
Diode chip thickness -width-length	$100 \mu\text{m} - 200 \mu\text{m} - 200 \mu\text{m}$
Antenna coupling efficiency	0.5

Table I

The measured embedding impedances for the conventional 4λ whisker were as follows:-

$$Z_{\text{emb}}(f_{\text{LO}}) = 133.6 - j 5.0; \quad Z_{\text{emb}}(2f_{\text{LO}}) = 82.7 - j 11.0; \quad Z_{\text{emb}}(3f_{\text{LO}}) = 62.5 + j 18.9;$$

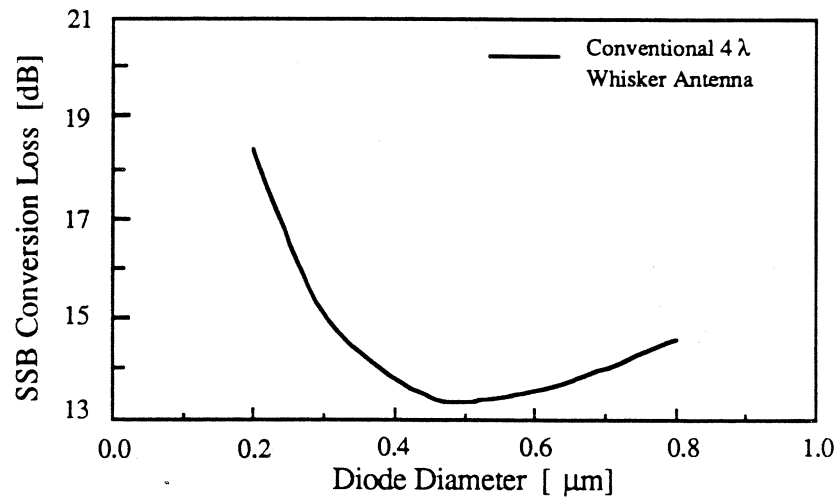

fig 7

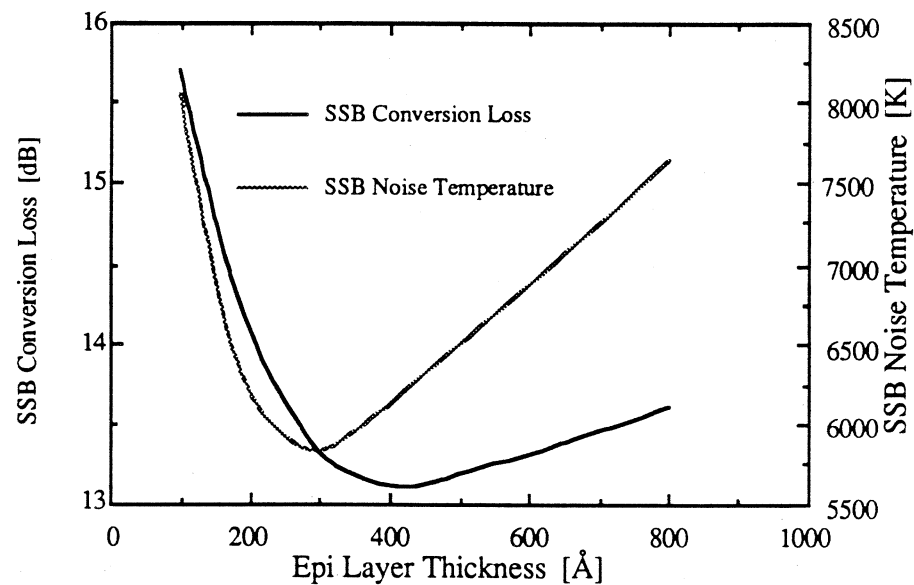

fig 8

The impedances for the signal side bands are assumed to be the same as those used for the corresponding LO harmonics. This is considered reasonable bearing in mind the low IF frequency used. The predicted performance for this mixer configuration gives reasonable agreement to that measured in the real device⁶. The program was used to determine the effect of various diode parameters. Figure 7 shows how the conversion loss of the mixer varies as function of diode diameter. Decreasing the diameter should initially give an improvement in performance which eventually reverses to a degradation for very small diodes. The effect of varying the epi-layer thickness is shown in figure 8. These trends are currently under investigation and diodes having the theoretically optimised parameters are now being fabricated for assessment. The only truly valid way of verifying the model is to vary the mixer format in a controlled way and check that the change in the device's performance agree

with the predictions. This will require a comprehensive iterative investigation during which full control over both diode and antenna parameters will be essential

DISCUSSION

The main finding of this work is that the embedding impedance presented to the diode will essentially be independent of the whiskers diameter and length of the first section. This is true provided that the first bend in the whisker is not too sharp and that the final termination is not made too close to the bend. If the first bend in the whisker is made too sharp a standing wave will be present on the whiskers first section. The reactive component of the embedding impedance can then be substantial allowing the real component to be varied as a function the first section length. A similar argument applies if the final termination of the whisker is positioned too close to the bend.

Obviously the technique used has it's limitations, for instance the scaling of the real mixers surface finish was not possible and discrepancies due to the skin effect have not been considered. However, these measurements do show the tendencies of embedding impedance variation with whisker tip parameters which will also be present in the real device. For example, when the whisker diameter is reduced, the tendency for the characteristic impedance of the whisker antenna to increase is apparent.

These results suggest that only a limited improvement in performance could be found by varying the whisker diameter (D). Experience gained during the optimisation of lower frequency ($\approx 350\text{GHz}$) Schottky diode mixers in waveguide would suggest caution however. Mixers assembled using only $12\mu\text{m}$ diameter whisker wire displayed a wide variation in performance even though near identical whiskers were used. This was finally traced to undesirable effects related to the excess pressure exerted on the diode anode by the whisker tip. This resulted in an increase in the diode noise and a degradation of the diode characteristic. Only when these effects were removed by improving the contacting process was it possible to optimise the devices in an understandable manner. The force exerted by a whisker is proportional to D^4 so it is likely that similar effects may be present for current corner cube mixers. It is possible that the use of thinner whisker wire will result in improved performance whereas these results suggest that it should not. The reduction in the force exerted on the diode may lead to an overall improvement even though the RF match to the diode has not changed.

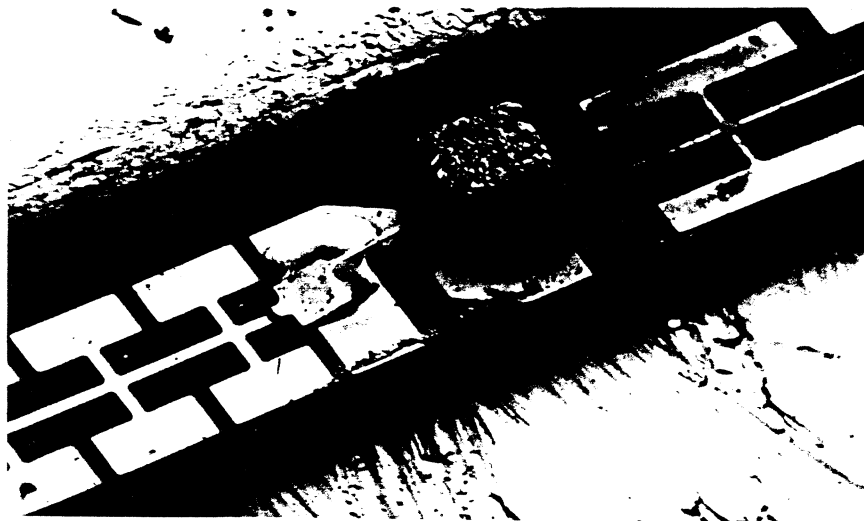

fig 9

The physical resilience of the structure could be improved dramatically if the diode were contacted using a much shorter whisker. This can be achieved by fixing both the diode and the contacting whisker to a dielectric substrate^{6,7}. The antenna element of the mixer can then be fabricated using photolithographic techniques. Techniques which make the assembly of such small circuits possible are now becoming available. Figure 9 shows a circuit designed for operation in waveguide at 600GHz {fabricated by the Millimetre Wave Technology group at the Rutherford Appleton Laboratory, Oxon, UK}. The circuit has been realised using a novel 5 μ m wide quasi-planar whisker which is contacted to the 1 μ m diode and then fixed in place using Indium solder. The rough cylinder lying alongside the substrate is a human hair approximately 70 μ m in diameter. The contacting process is controlled with great precision using stepper motor drives and piezo-electric pressure transducers to determine safe limits for the force acting on the diode. Further work is currently underway but already the concept shows great promise and ideally lends itself to terahertz devices.

ACKNOWLEDGEMENTS

We would like to thank the Millimetre Wave Technology group at the Rutherford Appleton Laboratory for making available details of the Quasi-Planar technology.

REFERENCES

- [1] "The Coupling of Submillimeter Corner-Cube Antennas to Gaussian Beams", E. N. Grossman, *Infrared Phys.* Vol. 29, pp.875-885, 1989
- [2] "A Corner-Reflector Mixer Mount for Far Infrared Wave Lengths", J.Zmuidzinas, A. L. Betz, R. T. Boreiko, {Accepted for Publication in *Infrared Physics*}.
- [3] "Theoretical and Experimental Analysis of a Waveguide Mounting Structure", R. L.Eisenhart and P. J. Khan, *IEEE Trans. on MTT*, Vol MTT 19. Pg 706-719, Aug 1971.
- [4] "Improved Coupling to Infrared Whisker Diodes by use of Antenna Theory", Matrese, L.M. and Evenson, K.M., *Appl. Phys. Lett.*, 17, no.1, pp.8-10, July 1970.
- [5] P. H. Siegel, A. R. Kerr, W. Hwang, NASA Technical Paper 2287, March 1984.
- [6] "Low Noise GaAs Schottky diode for Submillimeter Wave Detectors/Mixers", T. Suzuki, H. Shinohara, K. Mizuno, H. P. Roser, R. Titz, *The 3rd Asia-Pacific Microwave Conference Proceedings*, Tokyo, 1990
- [7] "183GHz Double Diode Subharmonically Pumped Mixer", C M Mann, D N Matheson, M R B Jones. *Int. J. of Infrared and Millimeter Waves*. Vol.10. No 9. 1989.
- [8] "A Novel 183GHz Subharmonic Schottky Diode Mixer", C M Mann, PhD Thesis, Queen Mary and Westfield College, University of London. May 1992.