

# Measurements with a Diffusion-Cooled Nb Hot-Electron Bolometer Mixer at 1100 GHz

A. Skalare, W.R. McGrath, B. Bumble, H. LeDuc

Center for Space Microelectronics Technology,  
Jet Propulsion Laboratory, California Institute of Technology,  
Pasadena, CA 91109

## Abstract

In this paper we report receiver sensitivity measurements with a diffusion-cooled niobium hot-electron bolometer around 1100 GHz. The lowest receiver noise temperature was 1670 K DSB, with approximately 40 nW of local oscillator power being dissipated in the device. The intermediate frequency bandwidth of this device, due to its short length (0.15  $\mu\text{m}$ ) and low normal resistance (43  $\Omega$ ), exceeded the 1.8 GHz bandwidth of the measurement setup. The receiver was used to detect the sulfur dioxide gas absorption line at 1102 GHz in a heterodyne mode.

## Introduction

In the last few years, superconducting Hot-Electron Bolometers (HEB's) [1-3] have emerged as the detectors of choice for low-noise heterodyne receivers at frequencies exceeding 1 THz. Funding has already been allocated, and receiver development has begun within both airborne (National Aeronautics and Space Administration's SOFIA) and spaceborne (European Space Agency's FIRST) projects. Critical issues to this technology, in addition to achieving low receiver noise temperatures, are the RF and IF bandwidths and the very limited amount of local oscillator (LO) power that would likely be available in a spaceborne mission.

Our earlier measurements [4] have shown that a relatively low receiver noise temperature, 1880 K DSB at 1267 GHz, can be achieved with an HEB using as little as 6 nW of dissipated LO power. For the same reason that this device required such low LO power,

namely its high resistance (140  $\Omega$ ), it also showed some effects of direct detection in the receiver Y-factor measurements. The purpose of the experiments reported here is to confirm the older measurements with a lower resistance device that does not exhibit these direct detection effects.

## The Device

The bolometer was a 0.15  $\mu\text{m}$  long and 0.15  $\mu\text{m}$  wide strip of niobium of with an approximate thickness of 10 nm on a Z-cut crystal quartz substrate. The device was fabricated with normal metal (gold) contacts in a self-aligned process [5]. A similar device is shown in Fig.1. Fig.2 shows the resistance versus temperature curve for the device used in the measurements. As can be seen, the normal state resistance was approximately 43  $\Omega$ . The critical current of the device was 200  $\mu\text{A}$  at 4.2 K ambient

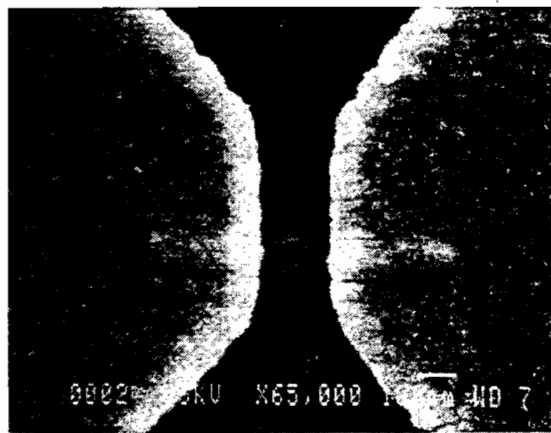

Fig. 1; SEM of an HEB device similar to the one used in the reported measurements.

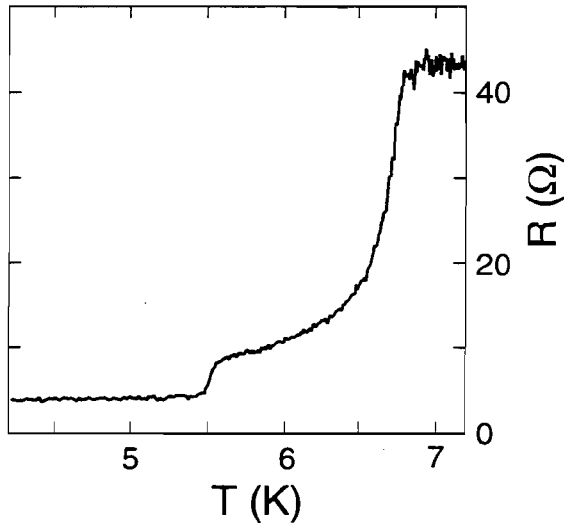

Fig. 2; Resistance versus temperature curve for the HEB mixer.

temperature. A gold planar double-dipole antenna with a center frequency of 1 THz was integrated on-chip with the HEB device [6-7].

### Measurement of Receiver Noise

The HEB chip was glued to the back of a hyperhemispheric crystal quartz lens with a diameter of 13 mm. A hyperbolic polyethylene lens in front of this quartz lens was used to increase the f-number of the antenna beam. To eliminate the back lobe of the dipole antenna, a quarter-wavelength thick crystal quartz chip with a gold mirror was glued on top of the HEB chip. The device was shunted in the DC bias circuit by a 17 Ω resistor. The DC shunt current through this resistor has been subtracted in the diagrams in this paper.

The fixture holding the device/lens assembly was placed in a liquid-helium cooled vacuum cryostat, that was connected to an evacuated box containing a 0.5 mil Mylar™ beamsplitter, a 295 K “hot” calibration load, an 82 K “cold” load that was cooled by liquid nitrogen, and a switch/chopper that allowed one or the other of the loads to be seen by the mixer, as shown in Fig.3. The calibration loads were made of Eccostock MF 116

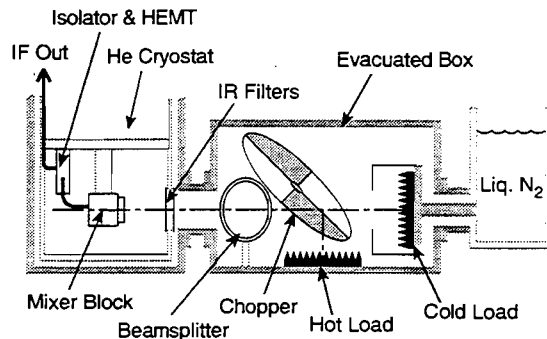

Fig. 3; Schematic of the cryostat containing the mixer and of the measurement box with the hot and cold calibration loads. There are no windows between the cryostat and box, but there are two Zitex™ infrared filters in the optical path.

microwave absorber with the surface machined into pyramids. The cold load also had several baffles coated with an absorbing paint to reduce room-temperature thermal radiation influx to the load, and to eliminate any scattering off the microwave absorber. A backward-wave oscillator (BWO) was used as the local oscillator. An isolator and an L-band cooled HEMT amplifier with a combined input noise temperature of 6.3 K were used as the first stage in the intermediate frequency (IF) system. A bandpass filter in the room temperature part of the amplifier-chain defined the IF bandwidth in the Y-factor measurements to about 300 MHz, centered around 1.4 GHz.

The receiver equivalent noise temperature was determined through a Y-factor measurement by switching between the hot and cold calibration loads. At a mixer ambient of 4.2 K, the lowest measured receiver noise temperature was 3050 K double-sideband (DSB) at a local oscillator (LO) frequency of 1107 GHz. No corrections for beamsplitter losses or other losses were made in calculating the receiver noise, but the thermal radiation from the calibration loads was assumed to be in the Rayleigh-Jeans limit. The local oscillator power that was absorbed in the device was estimated from the DC current-voltage (IV) characteristic to be 20 nW. In a separate Y-factor measurement, the mixer ambient temperature was reduced to 1.9 K, resulting in a lowest receiver noise

temperature of 1670 K DSB at an LO frequency of 1103.5 GHz. This data is shown in Fig.4 . This receiver noise temperature includes an IF system contribution of 470 K DSB, referred to the receiver input. The conversion loss was approximately 18 dB DSB, including an estimated 5 to 8 dB of RF coupling losses. No significant level of direct detection was evident in the measurements at either 1.9 K or 4.2 K.

The niobium film quality in the tested device was very high, and as a result the critical current was comparatively large. At 1.9 K the critical current of the unpumped device was too high to be measured, due to protection diodes and resistors in the DC bias network. Therefore the absorbed LO power could not be directly deduced by comparison of the pumped and unpumped IV curves. A rough estimate of 40 nW, however, could be made from the estimated LO power at 4.2 K, and by using the analytic expression for the temperature distribution in the microbridge. This approach assumes that the electron temperature at the center of the bridge is close to the critical temperature, and takes into account that the measured DC dissipated power at the optimum LO pump level was approximately 20 nW at both 1.9 K and 4.2 K.

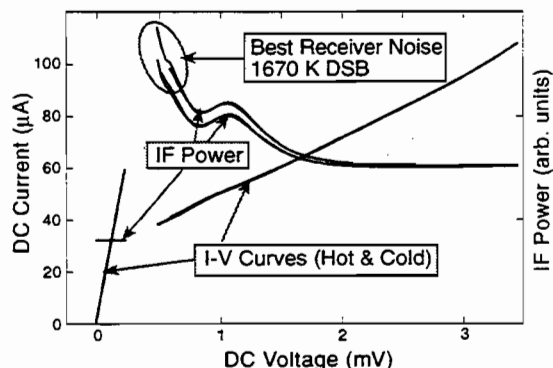

Fig.4; The DC IV curves and IF power versus DC voltage curves with the receiver looking at the 295 K and 82 K calibration loads. These curves were measured at an ambient temperature of 1.9 K, and gave a lowest receiver noise temperature of 1670 K DSB.

### Measurement of a Gas Spectral Line

As a verification of the heterodyne response, an absorption line measurement using a gas cell was made. Sulfur dioxide was chosen for this experiment, since this gas has several strong lines around 1100 GHz. Transmission spectra for three different gas pressures were measured by sweeping the BWO frequency and detecting the transmission with a commercial silicon bolometer cooled to 4.2 K. The spectra were normalized by a transmission measurement with an empty gas cell, and are shown in Fig.5 .

A multichannel spectrometer such as an AOS or autocorrelator was not available for the experiment described here, so instead the set-up shown in Fig.6 was used. The IF bandpass filter that was used in the Y-factor measurements was removed to increase the available bandwidth. The intermediate frequency output from the receiver was instead filtered to a 1 MHz bandwidth using a microwave spectrum analyzer, and this filtered signal was measured with a coaxial diode detector and a lock-in amplifier. The lock-in amplifier was synchronized to a 40 Hz chopper, which switched the receiver input between the 295 K and the 82 K calibration loads. This laboratory set-up had a considerably lower signal-to-noise ratio than the back-end spectrometers mentioned above, but was sufficient for the intended demonstration. This measurement was made at an ambient mixer temperature of 4.2 K.

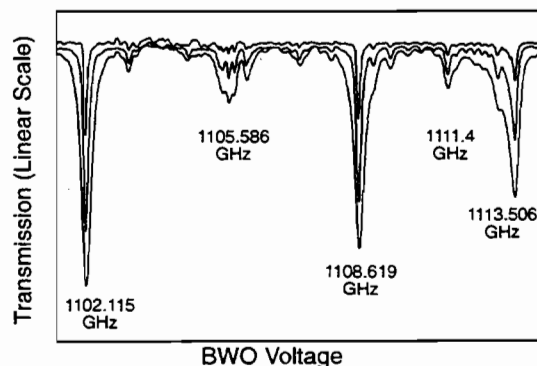

Fig.5; The transmission spectrum of the sulfur dioxide calibration gas, from a direct-detection measurement using a silicon bolometer. The three curves were measured at three different gas pressures.

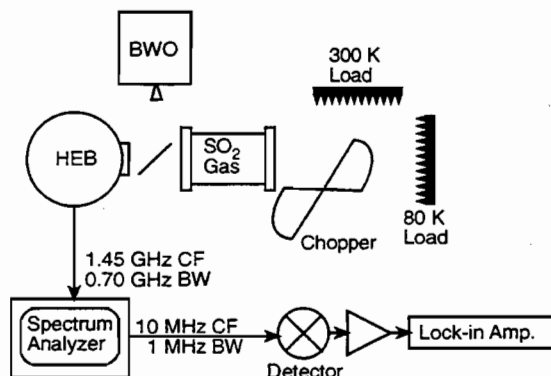

Fig. 6; Block diagram of the laboratory set-up for the gas cell measurement. A spectrum analyzer was used as a tunable IF filter.

Fig.7 shows three IF spectra, where the 1102.115 GHz sulfur dioxide line was detected in the lower sideband of the HEB receiver for different local oscillator frequencies. The spectra were normalized to a measurement with an empty gas cell to cancel out gain variations in the intermediate frequency amplifier chain. The gas line appears as a dip, since the chopped calibration loads are obscured from the mixer right at the line frequency (where the gas is optically thick), while they are visible at frequencies where the gas is optically thin. The frequency of the line shifts through the IF band in the expected way as the local oscillator frequency is changed, which shows that the response is heterodyne. A measurement of the mixer sideband ratio is in progress, which will allow us to fully quantify the heterodyne response, and will be reported at a later date.

During the preparations for the spectral measurement above, a series of measurements were made to accurately calibrate the BWO output frequency as a function of anode voltage and current. This was done by measuring transmission spectra of sulfur dioxide by sweeping the BWO anode voltage for several specific values of the anode current, which was adjustable by changing the cathode heater current. The detector in this measurement was a silicon bolometer. The two strong absorption lines at 1102.115 GHz and 1108.619 GHz were used as frequency references in the calibration. As expected, the

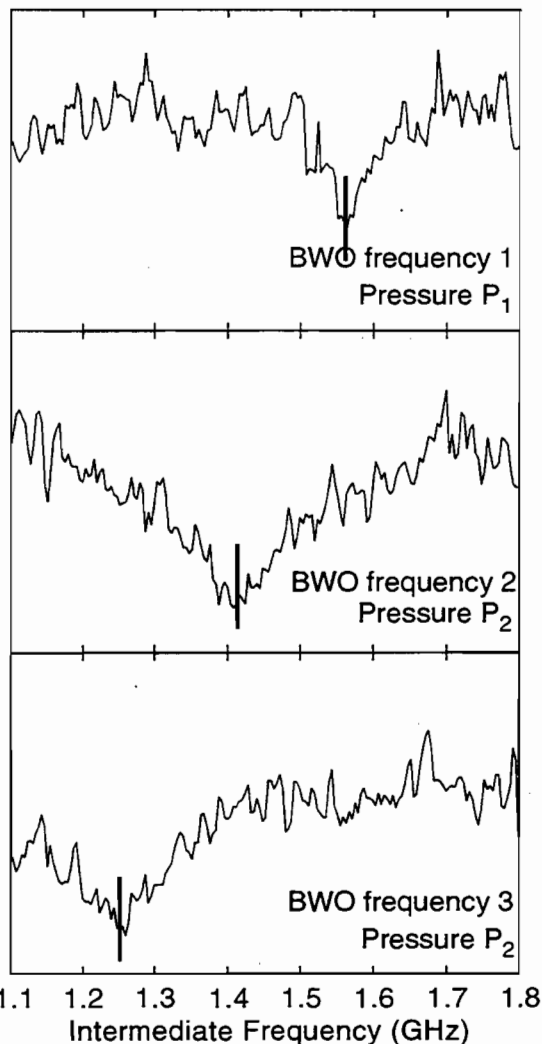

Fig.7; The 1102.115 GHz sulfur dioxide gas line detected in the lower sideband of the HEB receiver for three different local oscillator frequencies.

main factor in determining the frequency was the anode voltage, but the frequency was also found to change in a linear way with the anode current. This shift was almost 2 GHz over the useful range of the anode current (23 to 37 mA). It was therefore necessary to take the anode current into account when calculating frequencies during the mixer measurements, where the cathode heater current was often changed to adjust the amount of local oscillator power.

## Intermediate Frequency Bandwidth

The intermediate frequency dependence of the device conversion efficiency can be calculated from the hot/cold response if a correction is made for the frequency dependence of the IF amplifier chain. In this experiment the hot/cold response was measured by the lock-in technique described in the previous section. The IF calibration was done by heating the mixer to the critical temperature of the niobium film and applying a DC voltage of several millivolts. Under these conditions the average temperature in the niobium film, and therefore the thermal noise generated, changes in proportion to (small) changes in bias voltage. This means that the frequency dependence of the IF system gain, excluding the HEB device matching but including the spectrum analyzer and the lock-in amplifier, could be measured through lock-in detection by applying a 40 Hz bias modulation. Fig.8 shows the lock-in detected RF hot/cold response and the response to the DC bias modulation. The "calibrated" conversion efficiency in the figure is calculated by dividing these two curves. As can be seen, the calibrated response is essentially flat over the entire 1.1 to 1.8 GHz band. This indicates that the IF roll-off frequency of this device is well over 1.8 GHz, which is consistent with measurements of similar devices [8-9].

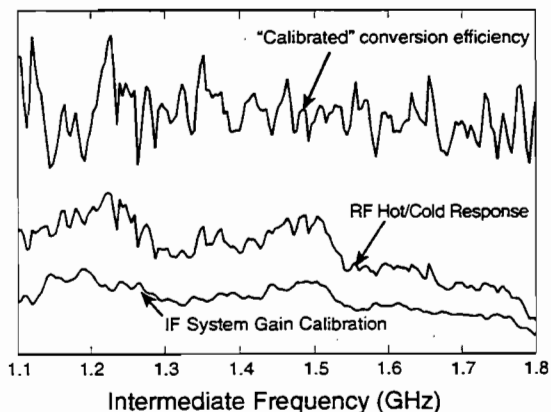

Fig.8: The RF hot/cold response, the IF system gain and the conversion efficiency calculated as the ratio of the two curves. No roll-off in the response is seen. This measurement was made at an ambient temperature of 4.2 K.

## Summary

Receiver noise measurements have been made with a niobium hot-electron bolometer, yielding a best receiver noise temperature of 1670 K DSB at a local oscillator frequency of 1103.5 GHz and an ambient temperature of 1.9 K. The total conversion loss in the mixer, including RF coupling losses was 18 dB. The amount of absorbed local oscillator power is estimated at around 40 nW. The IF conversion bandwidth of the bolometer exceeds 1.8 GHz. The best receiver noise measured with this device is slightly lower than in our previous experiments, and showed no evidence of direct detection.

The 1102.115 GHz absorption line in sulfur dioxide gas was detected in the intermediate frequency band of our HEB receiver, showing that the response is heterodyne.

## Acknowledgments

The research described in this paper was performed by the Center for Space Microelectronics Technology, Jet Propulsion Laboratory, California Institute of Technology, and was sponsored by the National Aeronautics and Space Administration, Office of Space Science.

## References

- [1] E.M. Gershenzon, G.N. Gol'tsman, I.G. Gogidze, Y.P. Gusev, A.I. Elant'ev, B.S. Karasik, A.D. Semenov, "Millimeter and submillimeter range mixer based on electronic heating of superconducting films in the resistive state," *Sov. Phys. Superconductivity*, Vol.3(10), pp.1582-1597, 1990
- [2] D.E. Prober, "Superconducting Terahertz Mixer using a Transition-Edge Microbolometer," *Appl. Phys. Lett.*, Vol.62(17), pp.2119-2121, 26 April 1993.

- [3] E.L. Kollberg, "Superconducting mixers for submillimetre wavelength," Book chapter in *New Directions in Terahertz Technology*, J.M. Chamberlain, R.E. Miles (ed.), Kluwer Academic Publishers, Dordrecht, the Netherlands, 1997, ISBN 0-7923-4537-1.
- [4] A. Skalare, W.R. McGrath, B. Bumble, H.G. LeDuc, "Receiver Measurements at 1267 GHz using a Diffusion-Cooled Superconducting Transition-Edge Bolometer," *IEEE Trans. Applied Superconductivity*, Vol.7(2),pp.3568-3571, June 1997.
- [5] B. Bumble, H.G. LeDuc, "Fabrication of a Diffusion Cooled Superconducting Hot Electron Bolometer for THz Mixing Applications," *IEEE Trans. Applied Superconductivity*, Vol.7(2),pp.3560-3563, June 1997.
- [6] P.T. Parrish, T.C.L.G. Sollner, R.H. Mathews, H.R. Fetterman, C.D. Parker, P.E. Tannenwald, A.G. Cardiasmenos, "Printed Dipole-Schottky Diode Millimeter Wave Antenna Array," *SPIE Millimeter Wave Technology*, pp.49-52, Vol.337, 1982.
- [7] A. Skalare, Th. de Graauw, H. van de Stadt, "A Planar Dipole Array Antenna with an Elliptical Lens," *Microwave and Optical Tech. Lett.*, Vol.4, No.1, Jan 5, 1991.
- [8] P.J. Burke, R.J. Schoelkopf, D.E. Prober, A. Skalare, W.R. McGrath, B. Bumble, H.G. LeDuc, "Length Scaling of Bandwidth and Noise in Hot-Electron Superconducting Mixers," *Appl. Phys. Lett.* 68(23), 3 June 1996.
- [9] B.S. Karasik, M.C. Gaidis, W.R. McGrath, B. Bumble, H.G. LeDuc, "Low noise in a Diffusion-Cooled Hot-Electron Mixer at 2.5 GHz," *Appl. Phys. Lett.* 71(11), 15 September 1997.