

EECS 373 *Midterm*

Winter 2014

Name: _____ unique name: _____

Sign the honor code:

I have neither given nor received aid on this exam nor observed anyone else doing so. Nor did I discuss this exam with anyone after it was given to the rest of the class.

Scores:

# Page	Points
2	/12
3	/10
4	/15
6	/18
9	/30
10	/15
Total	/100

NOTES:

1. Closed book/notes and no calculators.
2. There are 11 pages including this one. *The last page is a reference sheet. You may wish to rip it out.*
3. Calculators are allowed, but no PDAs, Portables, Cell phones, etc.
4. Don't spend too much time on any one problem. If you get stuck, move on!!!
5. You have about 80 minutes for the exam.
6. **Be sure to show work and explain what you've done when asked to do so.**
Getting partial credit without showing work will be rare.
7. **Throughout the exam "standard logic gates" means arbitrary input ANDs, ORs, NANDs, NORs, XORs and XNORs as well as NOT gates.**

1) Multiple-choice/fill-in-the-blank [12 points, -2 per wrong or blank answer, minimum 0]

- a. In Verilog an @* block is used to create combinational logic / sequential logic / a flip-flop.
- b. 100 clock ticks of a 100MHz clock takes about _____ ns
- c. A _____ is when a combinational signal should stay at a level (0 or 1), but instead changes to the other level for a short time.
- d. When using an open collector scheme to drive wires on a bus means that if there are more than one devices trying to drive the bus in different ways the result will be a logical 1 / logical 0 / HiZ / creating a short circuit and letting out the "magic smoke".

- 2) Short answer. You should answer each question in three sentences or less. **[10 points]**
- a. Explain why 0x5555 and 0x55550000 can't both be instructions on the Cortex M3 **[5]**

3) Say we have three potential interrupt sources, external exception numbers 50, 51 and 52. 52 is to be capable of preempting the other two interrupts, and 51 should have a higher priority than 50, but not be able to preempt it. **The page following this one has a number of tables and other information that you may find useful when solving this problem.** [15 points]

a. Assuming PRIGROUP=6, provide priority levels for the three sources that would give the desired preemption and priority between them. Provide your answers as 8-bit numbers in hex. [3]

Priority level for 50: _____ Priority level for 51: _____

Priority level for 52: _____

b. Write a segment of ARM assembly code which sets the priority level for external exception number 50. [6]

c. Say that the interrupts and their ISRs had the following properties

Exception #	Time the interrupt occurs at	ISR run time
50	0ms	5ms
51	3ms	3ms
52	4ms	2ms

At what time will the ISR for exception 50 finish running? Clearly justify your answer. [6]

Table 7.5 Definition of Preempt Priority Field and Subpriority Field in a Priority Level Register in Different Priority Group Settings

Priority Group	Preempt Priority Field	Subpriority Field
0	Bit [7:1]	Bit [0]
1	Bit [7:2]	Bit [1:0]
2	Bit [7:3]	Bit [2:0]
3	Bit [7:4]	Bit [3:0]
4	Bit [7:5]	Bit [4:0]
5	Bit [7:6]	Bit [5:0]
6	Bit [7]	Bit [6:0]
7	None	Bit [7:0]

Table 7.4 Application Interrupt and Reset Control Register (Address 0xE000ED0C)

Bits	Name	Type	Reset Value	Description
31:16	VECTKEY	R/W	—	Access key; 0x05FA must be written to this field to write to this register, otherwise the write will be ignored; the read-back value of the upper half word is 0xF05
15	ENDIANNESS	R	—	Indicates endianness for data: 1 for big endian (BE8) and 0 for little endian; this can only change after a reset
10:8	PRIGROUP	R/W	0	Priority group
2	SYSRESETREQ	W	—	Requests chip control logic to generate a reset
1	VECTCLRACTIVE	W	—	Clears all active state information for exceptions; typically used in debug or OS to allow system to recover from system error (Reset is safer)
0	VECTRESET	W	—	Resets the Cortex-M3 processor (except debug logic), but this will not reset circuits outside the processor

Table 8.2 Interrupt Set-Pending Registers and Interrupt Clear-Pending Registers (0xE000E200-0xE000E21C, 0xE000E280-0xE000E29C)

Address	Name	Type	Reset Value	Description
0xE000E200	SETPEND0	R/W	0	Pending for external Interrupt #0–31 bit[0] for Interrupt #0 (exception #16) bit[1] for Interrupt #1 (exception #17) ... bit[31] for Interrupt #31 (exception #47) Write 1 to set bit to 1; write 0 has no effect Read value indicates the current status
0xE000E204	SETPEND1	R/W	0	Pending for external Interrupt #32–63 Write 1 to set bit to 1; write 0 has no effect Read value indicates the current status

Table 8.3 Interrupt Priority-Level Registers (0xE000E400-0xE000E4EF)

Address	Name	Type	Reset Value	Description
0xE000E400	PRI_0	R/W	0 (8 bit)	Priority-level external Interrupt #0
0xE000E401	PRI_1	R/W	0 (8 bit)	Priority-level external Interrupt #1
...	—	—	—	—
0xE000E41F	PRI_31	R/W	0 (8 bit)	Priority-level external Interrupt #31
...	—	—	—	—

- 4) Write an ARM assembly language procedure that implements the following C function in an EABI-compliant manner and conforms to the following signature. *Clearly comment your code* so we can figure out what we are doing and what value each register holds. Poorly commented/unclear code will get points removed. You are to assume “printit()” is an ABI-compliant function that already exists. **[18 points]**

```
uint32 Thing1(uint32 erf, uint32 x[])
{
    int y;

    printit(x[erf]);

    if(x[erf]>erf)
        y=x[erf];
    else
        y=x[1];
    return(y+1);
}
```

Vibration Sensing Design Problem

Engine knock occurs in a car engine when the piston fires before it should causing abnormal vibrations. Engine controllers monitor these vibrations and adjust the engine timing to prevent this. Your job is to monitor the vibrations and provide an alert to the engine management software when the vibrations become excessive.



Excessive vibration is determined by simply measuring the number of vibrations over some time interval. We don't want to use processor time to do this, so you will accumulate the counts with a simple 32-bit counter. Each low-to-high transition of the vibration sensor counts as a single vibration. The counter will be reset on regular basis (called the "sampling interval"). If the counter exceeds some fixed value (called the "count threshold"), an interrupt will be generated.

The sampling interval and count threshold are both to be writeable, while the current value of the counter tracking the number of vibrations during the sampling interval is to be readable. The hardware will specify both the sampling interval and the count threshold in terms of clock ticks of PCLK ticks. PCLK is 100MHz.

Hardware available:

The following hardware devices are available (you may use as many of each as you need).

- A 32-bit modulo¹ counter with enable and reset. Its inputs are clock and reset, while its output is simply the current count as a 32-bit number.
- A 32-bit comparator that has two 32-bit inputs (X and Y) and three outputs (X>Y, X==Y, X<Y).
- Standard gates, flip-flops, MUXes, and registers (with enable and reset as desired).

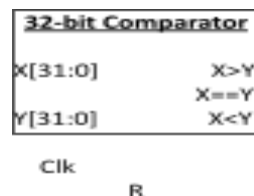
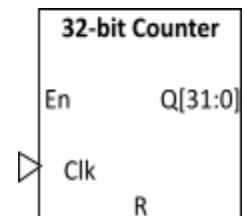

You will likely find it helpful to read the rest of the exam before solving any of the following parts.

¹ Recall that a "modulo" counter simply wraps around when it reaches its maximum value. So a 2-bit modulo counter would count 0,1,2,3,0,1,2,3,0, etc.

Interface to the APB bus

The kit has the following APB3 bus interface. The signal names are shown in bold. The APB3 bus signals follow APB3 timing and protocol. Read and write cycles are provided on the next page. PSEL is configured to be “1” when memory locations **0x40050000-0x4005000F** are accessed.

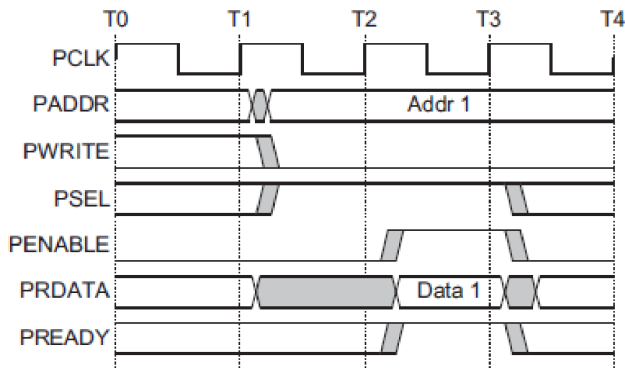
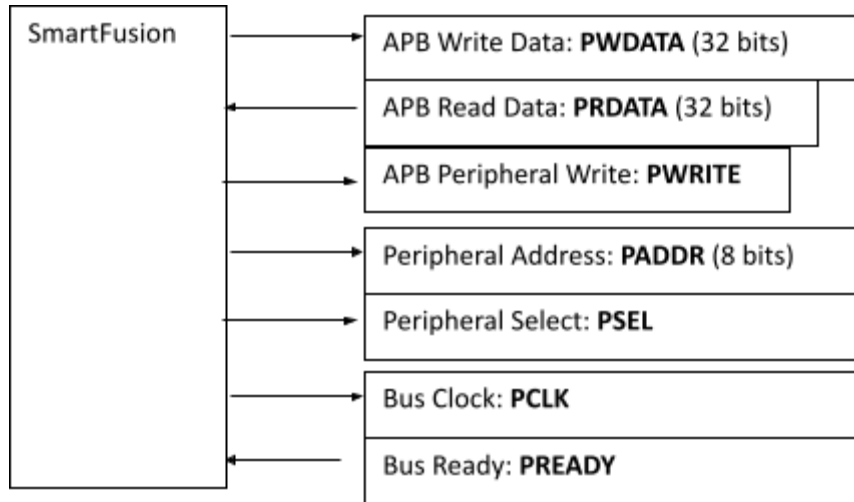

Figure 2-3 Read transfer with no wait states

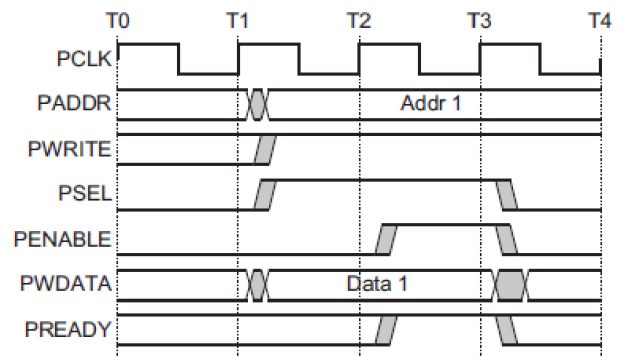

Figure 2-1 Write transfer with no wait states

Part 1: Hardware [30 points]

Provide APB3 interfaces to the timer and counter such that.

- A write to location **0x40050000** is to set the sampling interval to be the value written.
- A write to location **0x40050004** is to set the count threshold to be the value written.
- A read from location **0x40050000** returns the number of vibrations in this sampling interval.
- An interrupt is driven for one clock tick with when the number of vibrations in the current sampling interval *exceeds* the count threshold.

Shadow locations are acceptable.

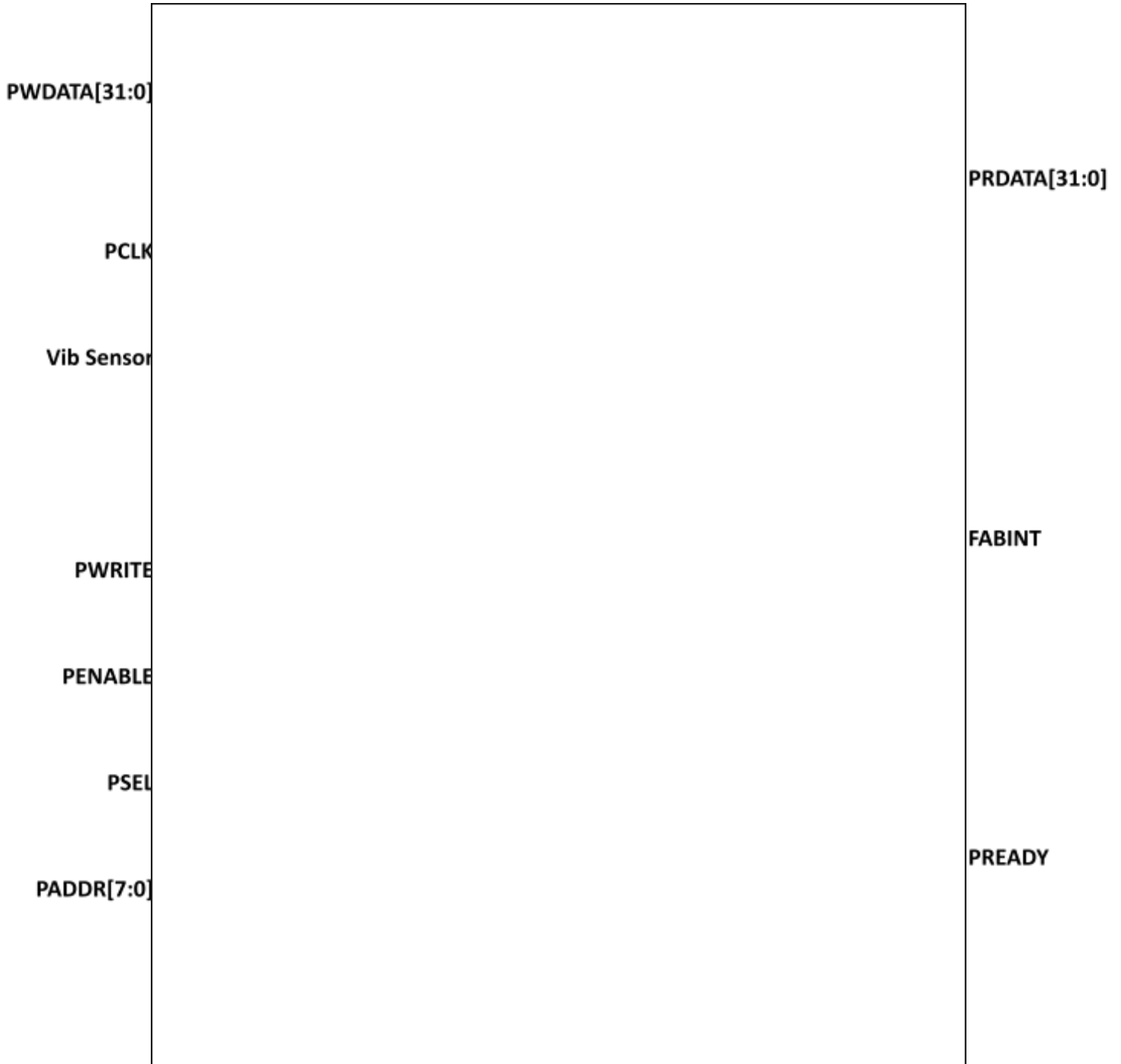

Part 2: Software [15 points]

You are to write an interrupt service routine in C that calls the function

```
void Knock_Alarm(int vibration_count, int sampling_interval)
```

and passes it the current vibration count and sampling interval. You are to provide the sampling interval in microseconds (rounding as desired if needed).

Note: you are to assume the function `Knock_Alarm()` has been already written!

```
__attribute__((interrupt)) void Fabric_IRQHandler( void ) {
```